



Chapter 11. Panini Scanner

OTCnet Participant User Guide

(This page intentionally left blank)

Audience, Overview and Topics

Audience

The intended audience for the *Panini Scanner Appendix* includes:

- Check Capture Administrator (CCA)
- Check Capture Supervisor (CCS)
- Check Capture Lead Operator (CCLO)
- Check Capture Operator (CCO)

Overview

Welcome to *Panini Scanner Appendix*. In this chapter, you will learn:

- How to install a Panini Vision X scanner
- How to install a Panini I: Deal scanner



Advanced Solutions
for Document Processing



Panini Vision X Operator Manual



Advanced Solutions
for Document Processing



CONTENTS

0. Preface

1. General

- 1.1 Audience
- 1.2 Safety Precautions
- 1.3 If the Machine is Damaged

2. Learning about the Panini Vision X

- 2.1 Packaging List
- 2.2 External Parts Description
- 2.3 Internal Parts Description

3. Operating your Panini Vision X

- 3.1 Document Support Installation
- 3.2 Extension Plate Installation
- 3.3 Power Cables Connection
- 3.4 USB 2 Cable Connection
- 3.5 HP C6602A Ink-Jet Cartridge Installation
- 3.6 Pocket Length Adjustment



Advanced Solutions
for Document Processing



4. Getting started

- 4.1 Status Lights
- 4.2 How to Prepare and Load Checks
- 4.3 Clearing Jams

5. Maintenance

- 5.1 Cleaning the Transport
- 5.2 Cleaning the Contact Image Sensors
- 5.3 Cleaning the HP C6602A Ink-Jet cartridge
- 5.4 Cleaning Photocells Detector
- 5.5 Replacing the Feeder and Separator Rollers
- 5.6 Cleaning the Reading Transport Belt
- 5.7 Install the External Covers

6. Specifications

- 6.1 Technical specifications of the Panini Vision X
- 6.2 Technical specifications of the PC

7. Vision X SD Addendum

8. Vision X AGP Addendum

9. Vision X P Addendum

10. Multilingual WEEE Disposal Procedure and Safety Precautions



Advanced Solutions
for Document Processing



**Second Edition:
February 2008**

© **2008**

PANINI SpA
Via Po, 39
10124 Torino Italy
Internet: www.panini.com

PANINI NORTH
AMERICA
(Subsidiary)
577 Congress Park Drive
Dayton, OH 45459
(USA)

This manual and the software described in it are protected under the Panini S.p.A Copyright. All rights reserved. Reproduction of this material in any form without the express written consent of Panini SpA or its subsidiaries is prohibited.

PANINI SpA PROVIDES THIS MANUAL "AS IS" WITHOUT WARRANTY OF ANY KIND, EXPRESS OR IMPLIED, INCLUDING, BUT NOT LIMITED TO THE IMPLIED WARRANTIES OF MERCHANTABILITY AND FITNESS FOR A PARTICULAR PURPOSE. PANINI SpA MAY MAKE IMPROVEMENTS AND OR CHANGES IN THE PRODUCT(S) AND OR THE PROGRAM(S) DESCRIBED IN THIS MANUAL AT ANY TIME AND WITHOUT NOTICE. This manual could contain technical inaccuracies or typographical errors. Changes are periodically made to the information herein; these changes will be incorporated in new editions of this publication.



Advanced Solutions
for Document Processing



Trademark Acknowledgement

PANINI, Vision X, Vision API, ICR Vision and MICR Plus are trademarks or registered trademarks of Panini SpA.

The mark  affixed to the product certifies that the product satisfies the basic quality requirements.



The Panini Vision X is also UL 950 compliant



NOTE: This equipment has been tested and found to comply with the limits for a Class A digital device, pursuant to Part 15 of the FCC Rules. These limits are designed to provide reasonable protection against harmful interference when the equipment is operated in a commercial environment. This equipment generates, uses, and can radiate radio frequency energy and, if not installed and used in accordance with the instruction manual, may cause harmful interference to radio communications. Operation of this equipment in a residential area is likely to cause harmful interference in which case the user will be required to correct the interference at his own expense.

© 2008 PANINI S.p.A., ALL RIGHTS RESERVED



Advanced Solutions
for Document Processing



Proper Disposal of WEEE

FOR COUNTRIES IN THE EUROPEAN UNION (EU)

The European Commission of the European Union has determined that electrical and electronic equipment on the market today contain parts and components that may be properly reused or recycled to reduce quantities of materials ultimately disposed in landfills and other disposal arenas. To address this determination, waste electrical and electronic equipment (WEEE) should not be collected or disposed with unsorted waste from private households or businesses. Rather, it must be collected separately. Dumping of these devices at unequipped and unauthorized places may have hazardous effects on health and environment. Offenders will be subjected to the penalties and measures laid down by the law.

To that end, Panini products are appropriately marked with the European Union WEEE Directive's crossed-out dustbin symbol to indicate the requirement for separate collection of electrical and electronic equipment put on the market after August 13, 2005, according to the WEEE directive 2002/96/EC (and subsequent amendments) and your national laws.



To dispose of our devices correctly:

- Contact the Local Authorities or local distributor, who will give you the practical information you need and the instructions for handling the waste correctly, for example: location and times of the waste collection centres, etc.
- When you purchase a new device of ours, give a used device similar to the one purchased to our distributor for disposal.

FOR OTHER COUNTRIES (NOT IN THE EU)

The treatment, collection, recycling and disposal of electric and electronic devices will be carried out in accordance with the laws in force in the country in question.



Advanced Solutions
for Document Processing



O. Preface

Here is an overview of the manual layout:

Chapter 1: "General" introduces you to all the general information regarding the manual or the Panini Vision X.

Chapter 2: "Learning about Panini Vision X" introduces you to all the major components of your machine.

Chapter 3: "Operating your Panini Vision X" describes simple installation procedures.

Chapter 4: "Getting started" explains how to operate the Vision X.

Chapter 5: "Maintenance" describes how to solve problems that you may encounter using this machine.

Chapter 6: "Specifications" lists the main functions of the Vision X and the features of the PC.



Advanced Solutions
for Document Processing



O. Preface

Chapter 7: "Vision X SD Addendum"

Chapter 8: "Vision X AGP Addendum"

Chapter 9: "Vision X P Addendum"

Chapter 10: "Multilingual WEEE Disposal Procedure and Safety Precautions" explains how to dispose the Vision X in 12 languages



1. General

Congratulations on your selection of the Panini Vision X!

The Panini Vision X is the next generation check scanning platform designed specifically for distributed check capture.

With a small footprint, sleek design and quiet operation, the Panini Vision X series is the ideal choice for a wide array of applications such as: Teller Window, Back Counter, Commercial Deposits, Microfilm Replacement, Cash Vault, Brokerage Houses, Accounts Receivable Conversion (ARC), just to name a few.

The Panini Vision X incorporates the latest, state-of-the-art technology and the latest standards for check processing in the marketplace. It is characterized by its ease of use and scalability.

A unique, patent-protected 3-mode feeder can be found in the Panini Vision X, allowing for single item feeding, up to 50 items batch feeding or up to 100 items batch insertion.

Panini Vision X image capture capabilities have been optimized in order to guarantee image integrity and perfect data readability despite variations in documents processed, operational skills, environmental and usage conditions.

MICR reading technology available with the Panini Vision X is comparable to the larger and faster reader sorter, thanks to the Panini MICR Plus™ technology.

Taking advantage of the most up to date technology, the Panini Vision X connects to computers via USB2.0 interface, allowing for fast data transfer at no additional cost.

A rear Ink-Jet endorser can also be found on the Panini Vision X.

The Panini Vision API is standard on the Vision X, guaranteeing easy and reliable software integration.

Finally, the Panini Vision X has been designed specifically to allow for entire track accessibility, including scanner area, for easy intervention and for maintenance purposes.



1.1 Audience

This manual is written primarily for personnel who process checks or other documents.

1.2 Safety Precautions

Before you begin operating or servicing your Vision X as instructed in this manual, please make sure you read and understand these important safety instructions.

- Dress safely. Do not wear loose clothing, long hair or jewelry that can become entangled in moving parts.
- Do not allow anything to rest on the power cord. Do not locate the Vision X where people may walk on the cord.
- Always unplug the Vision X before cleaning.
- Do not attempt to service or repair the Vision X, except as instructed elsewhere in this manual.
- Attempting to service or repair the external power supply of the Vision X may expose you to dangerous voltage points or other risks.
- Refer all servicing to qualified service personnel.



1.3 If the Machine is Damaged

Unplug the Vision X from the wall outlet and refer servicing to qualified personnel under the following conditions:

- If the power cord is damaged or frayed.
- If liquid has been spilled into the product.
- If the equipment has been exposed to rain or water.
- If the equipment does not operate normally when the operating instructions are followed.
- If the equipment has been dropped or damaged.
- If the equipment exhibits a distinct change in performance, indicating a need for service.

Adjust only those controls and replace only those items that are covered by the instructions in this manual. If you attempt to make adjustments not covered in this manual, you may damage the equipment and void the warranty.

Unauthorized adjustments or repairs may result in the need for extensive work by a qualified technician to return the equipment to its proper working condition.

2. Learning About the Panini Vision X

The Panini Vision X is a compact, easy-to-use and quiet scanner. The Panini Vision X automatically scans the front and/or rear of checks while simultaneously capturing the Magnetic Ink Character Recognition (MICR) code line. An optional Ink-Jet endorser prints alphanumeric characters on the rear of items. Any of the Windows standard fonts can be used for printing endorsements. The Panini Vision X is connected to a PC via a USB2.0 interface.

2.1 Packaging List

The Panini Vision X package includes:

- Operator Manual (1)
- Accessories box (2)*
- Panini Vision X scanner unit (3)
- Power cable (4)

(*) The accessories box contains:

- Feeder Extension
- Extension plate
- Ink-Jet Cartridge HP C6602A
(Panini P/N: CA-00138-00)
Cartridge not included with No Ink Jet (NJ) versions
- Ink-Jet Plastic Lever (adapter for HP 51604A cartridge)
- USB 2 Cable
- Power Supply

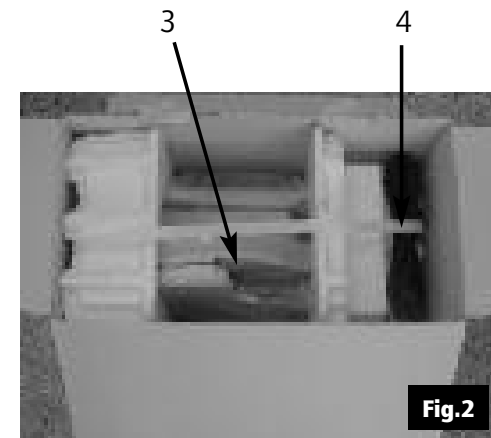
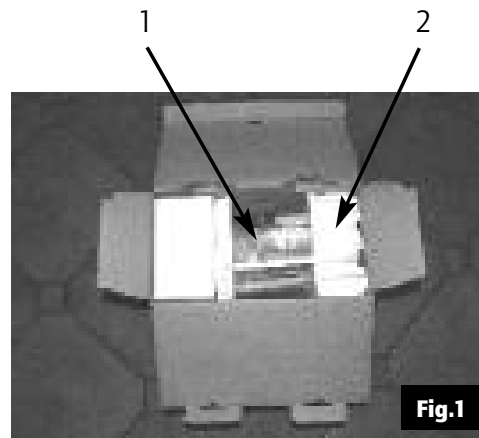

Removing the Panini Vision X from the Packaging

1. Remove the Accessories box, the operator manual and the power cable out of the packaging.
2. Holding the packaging down with one hand, lift the Vision X together with the packing materials making use of the plastic handle (Fig.3).

Plastic handle

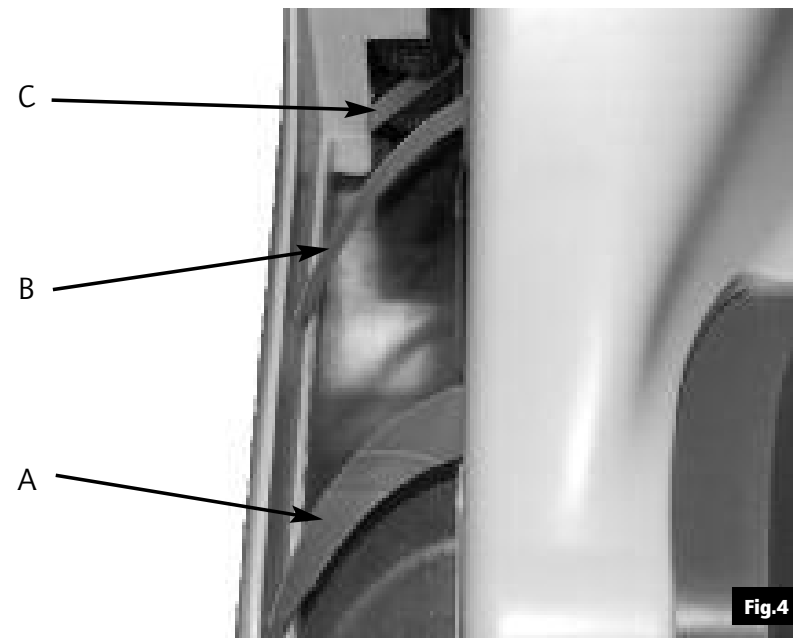
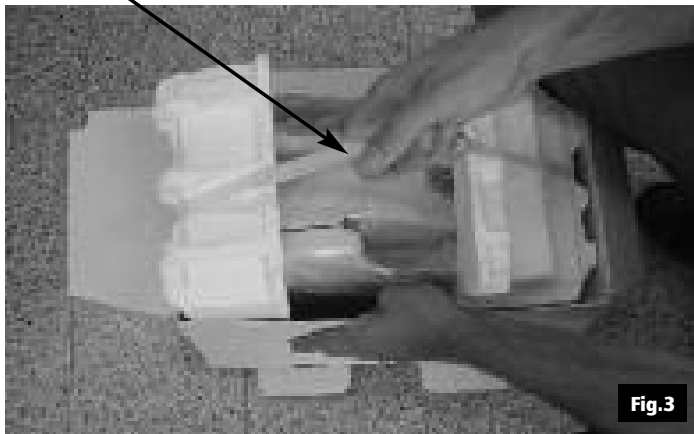

Attention:

- Don't use the plastic handle to carry the Vision X from one place to another. Use it only to extract the device from its packaging.
- During unpackaging, do not remove or pull the Mylar blades A, B and C (see Fig.4).

2.2 External Parts Description

This section describes the major components of the Panini Vision X. The component names introduced here and shown in the figures are used throughout this manual.

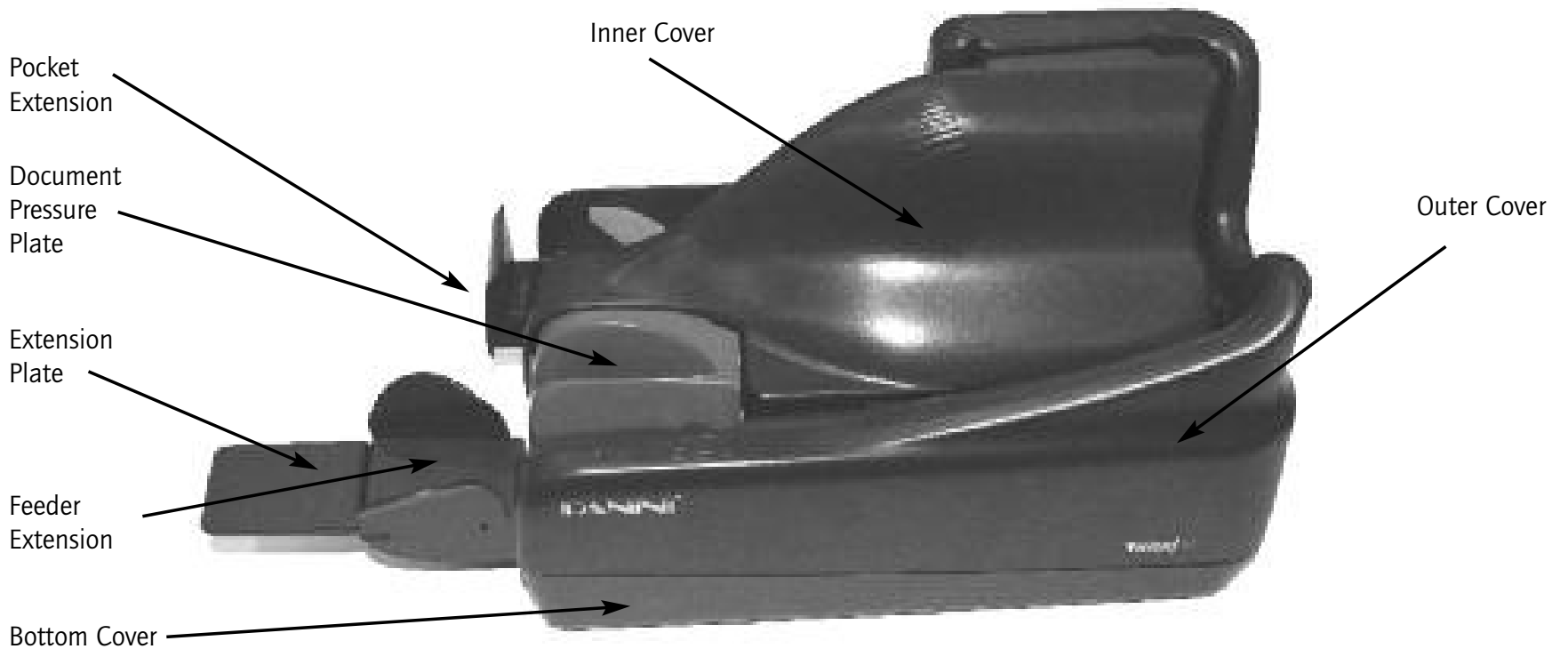
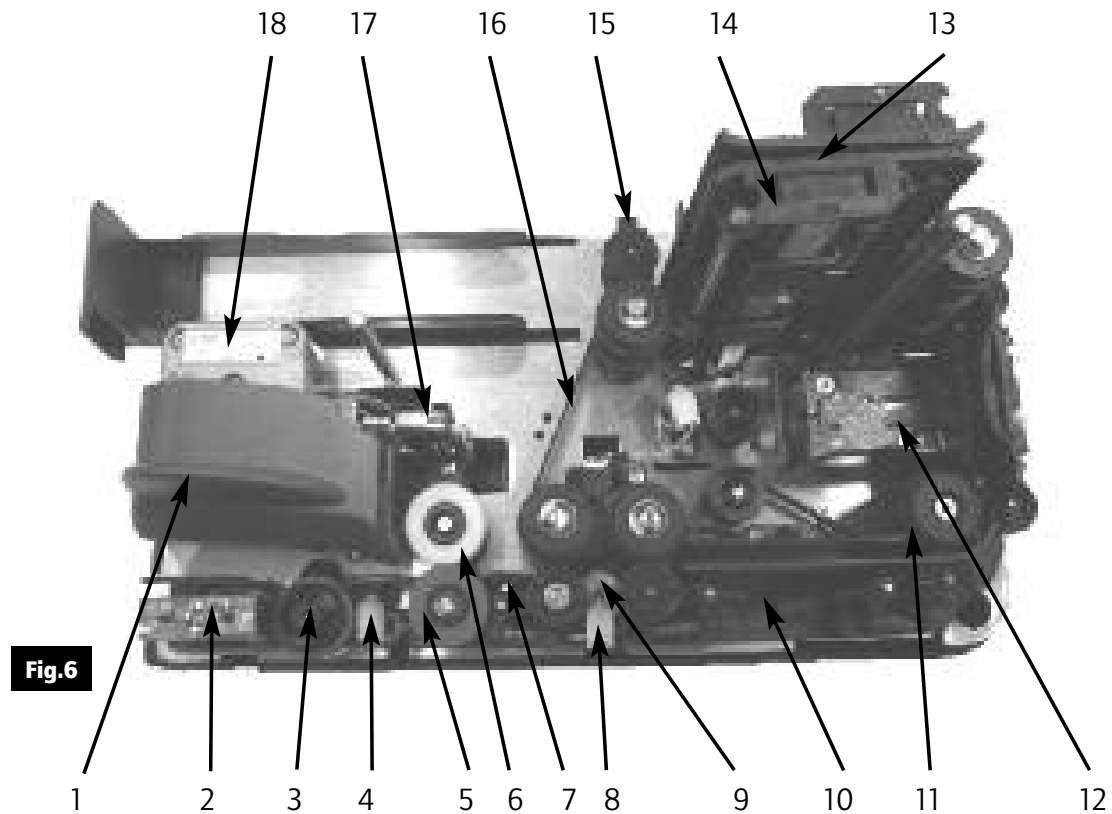

Fig.5

2.3 Internal Parts Description

- 1 Document Pressure Plate
- 2 LED board
- 3 Feeder Roller
- 4 Feeder Sensor
- 5 Separator Roller
- 6 Rear Separator Roller
- 7 Pre-magnetization Head
- 8 Synchronization Sensor
- 9 MICR Reading Head
- 10 "U" Track Wall
- 11 Transport Rollers
- 12 Ink-Jet Cartridge Cradle
- 13 Front Image Camera
- 14 Rear Image Camera
- 15 Pocket sensor
- 16 Transport Belt
- 17 Interlock Board
- 18 Feeder Motor



3. Operating your Panini Vision X

3.1 Document Support Installation

Insert the Feeder Extension in the slot uncovered by pushing back the Document Pressure Plate. Installation is correct if the Feeder Extension is at the same level of the entrance of the scanner platform.



3.2 Extension Plate Installation

The feeder extension is designed to support all documents anticipated to be processed by the Vision X. Markets or applications that process a large number of long documents (longer than 8 inches) may find it necessary to apply the optional extension plate for better document support, reducing the risk of image skewing, MICR rejects, etc. Assembly is made by sliding the extension plate, face side up, along the bottom side of the feeder extension into the support notches until the plate snaps into place (Fig.8). The lock tabs should securely fit into the round holes and the short and long tabs should be fully inserted into the support notches (Fig.9).

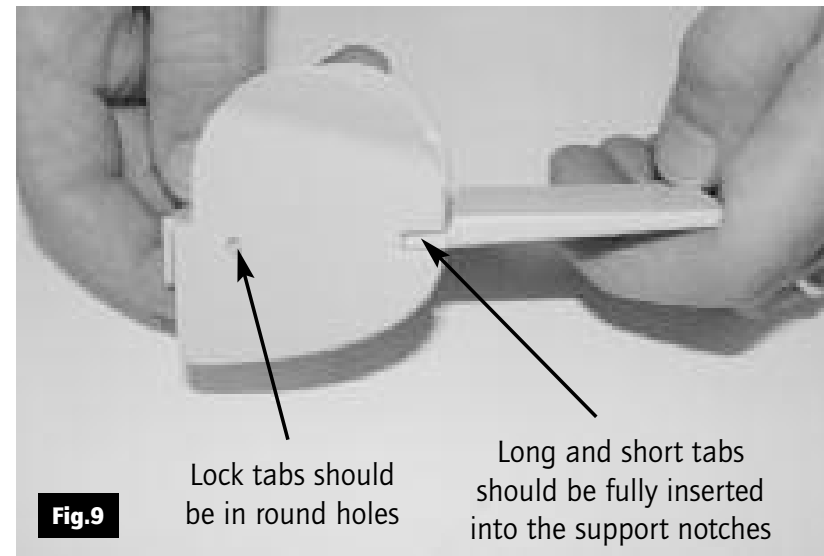
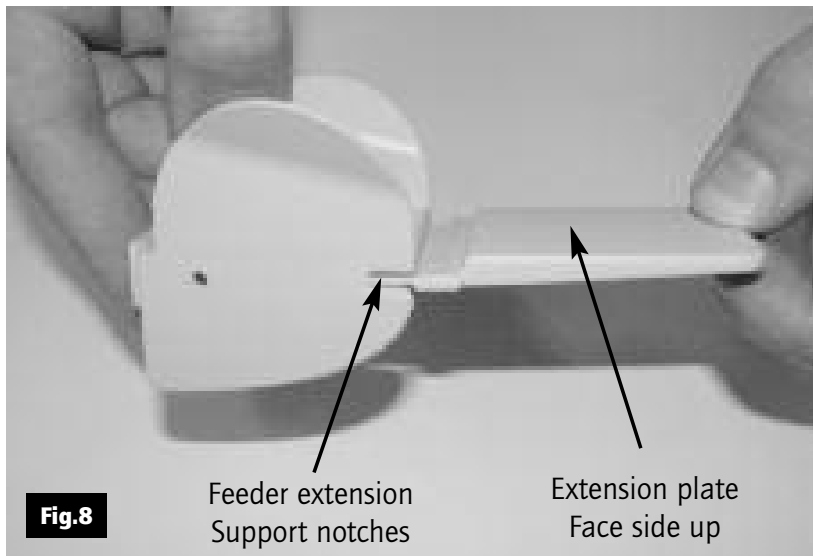

To remove, firmly grip the feeder extension and the extension plate and pull apart.

3.3 Power Cable Connection

Before connecting the scanner to your PC, make sure to locate the unit on a flat surface near the PC, away from direct light and from electromagnetic equipment.

1. Plug the power cord connector in the Power Supply socket (Fig.10).
2. Plug the Power Supply cable in the Vision X power connector (Fig.11).

Warning:

- The electromagnetic emission from a CRT monitor can produce interference and affect the MICR reading; therefore place the Vision X as far as possible from the CRT.
- The Vision X will be in compliance to the standard IEC/EN 60950-1 and UL 60950-1 only using the Power Supply model DSA-0421S-28 1 42 provided with the machine.



3. The Vision X should be plugged into a dedicated electrical power outlet. The socket outlet shall be installed near the equipment and shall be easily accessible. The power supply will be 100-240 VAC (no power selection required), and the frequency 50/60 Hz. If you are not sure of the type of power available, consult your Service Representative or local power company.

Note: There is no LED power indication upon connecting the Vision X. LED status indicators only illuminate when the application connects to the Vision X unit. See section 4.1.

3.4 USB 2 Cable Connection

Connect the USB 2 cable to the USB 2.0 port located on the rear side of the scanner, then connect the other end of the cable to an available USB 2.0 port on the PC.



USB 2 cable

Fig.12

3.5 HP C6602A Ink-Jet Cartridge Installation (*Optional)

Remove the inner cover (see section 5.1 for details).

Take a new Ink-Jet cartridge out from its package.

Do not touch the ink with your fingers or clothing: it will stain.

Angle the front side of the cartridge downwards and face the two pins with the two holes in the cradle.

Gently push down the rear side of the cartridge until it snaps in the plastic retainer.

* If the unit was purchased without the endorser option then the unit is shipped without an ink cartridge and that one is not needed to run the device.

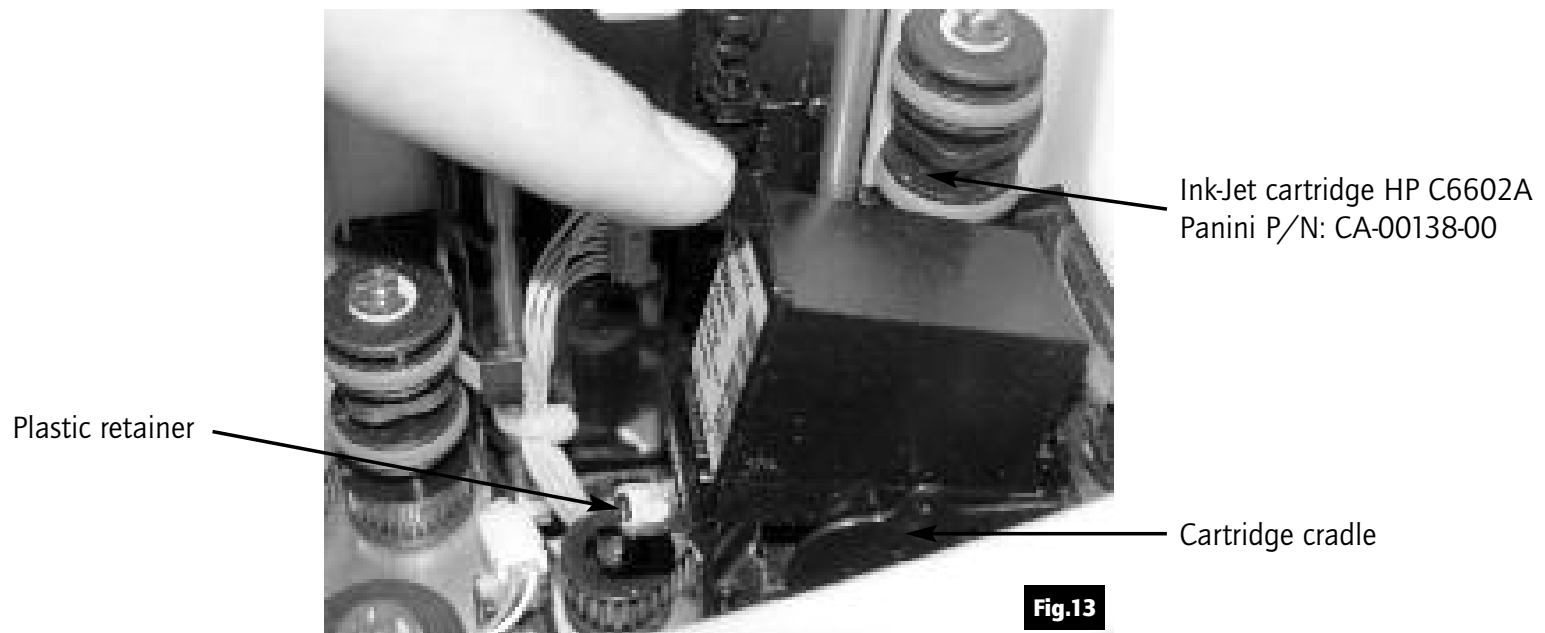

3.6 Pocket Length Adjustment

Adjust the pocket length by inserting the longest document that will be processed in the pocket. Move the pocket extension left or right until a space of 5 mm (1/4") is available between the leading edge of the document and the end of the pocket extension.

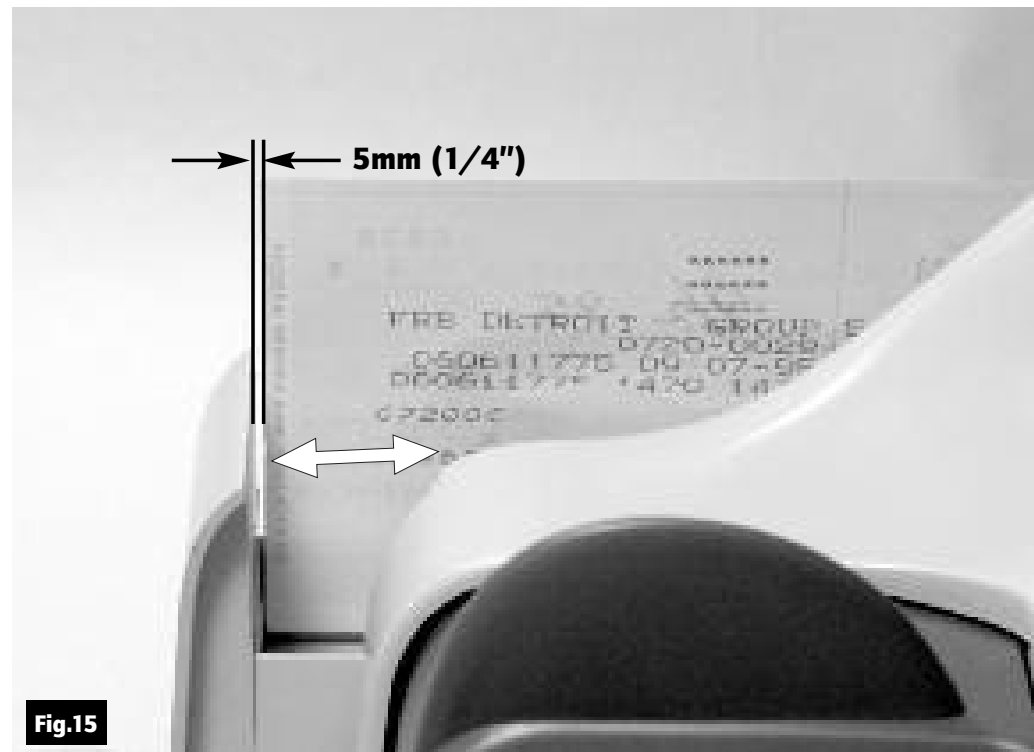

Fig.15



4. Getting Started

1. Turn on the PC.
2. Start the Vision X application (see note).
3. Follow the Vision X application instructions.
4. Load your checks.

Note: An application must be started before you begin to process documents. When the application starts, the Vision X turns on which is indicated by the green led in the outer cover.

If it is your job to start the application, refer to the documentation supplied with the application by the vendor.

Normally, the Vision X will automatically go on-line when the control application starts, and goes offline when the control application shuts down. If you want to force the reader to go offline even when the application is on, press the rear button switch for at least one second; at this point, the motor will briefly buzz and the green LED will turn off. To put the reader back on-line (only if the application is still running), press the button switch again for at least one second; the motors will briefly buzz and the green LED will turn on. Normally, this operation is allowed only when the Vision X is idle and will be ignored if the reader is working.

Pressing the button switch when the green LED is off will have no effect.

4.1 Status Lights

Two status lights located near the feeder indicate the status of the unit.

The following table describes the meaning of each status light.

Red LED	Green LED	Description
Off	Off	The Vision X is offline
Off	On	The Vision X is online and the feeder is empty
Off	Blinking	The Vision X is online and the feeder contains documents ready to feed
On	Off	Interlock switch is activated and the central plastic cover is removed
Blinking	Off	Jam on the transport track



Fig.16

Note: There is no LED power indication upon connecting the Vision X. LED status indicators only illuminate when the application connects to the Vision X unit.

4.2 How to Prepare and Load Checks

Preparing Documents for Processing

1. Remove all rubber bands, staples, paper clips, dog ears, etc. from the documents.
2. Jogging the documents is strongly recommended. In any case, align the bottom edges by repeatedly tapping the bottom edge of the documents on a hard, flat surface, see Fig.17.
3. Repeatedly tap the leading edge of the documents on a hard, flat surface, see Fig.18.
4. Check bottom and leading edges once more to ensure documents are aligned.

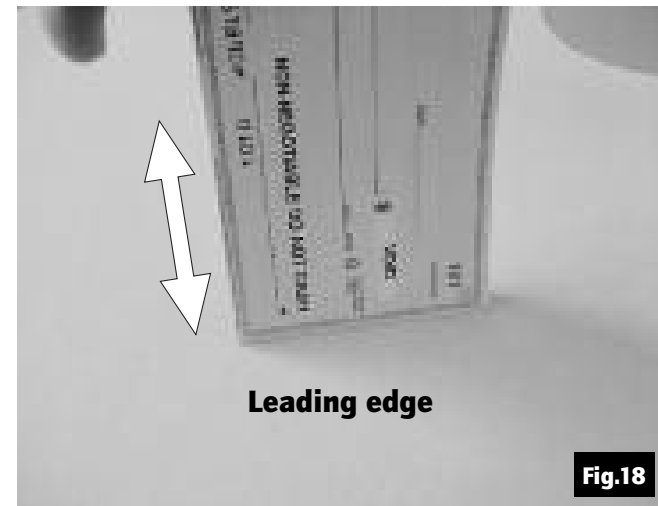
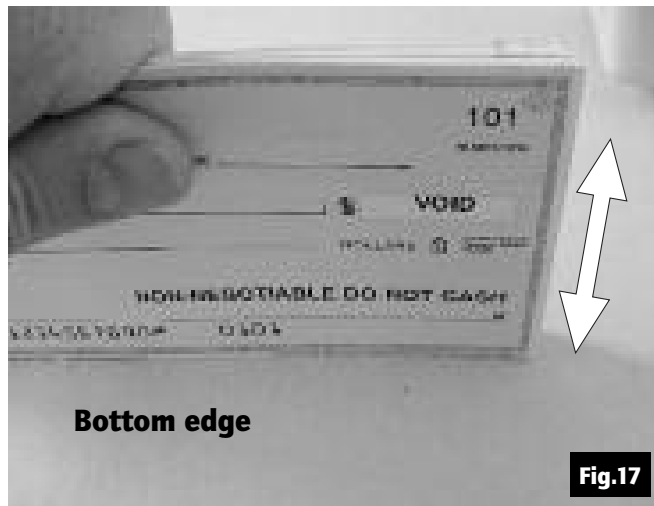

Tip: Use a mechanical jogger device for faster and more accurate alignment of bottom and leading edges.



Feeding Documents

You may feed documents one at a time or in small batches by inserting the documents all the way into the feeder. (Fig.19).

The documents must be inserted into the feeder so that the leading edge fits between the two black lines shown in Fig.20.

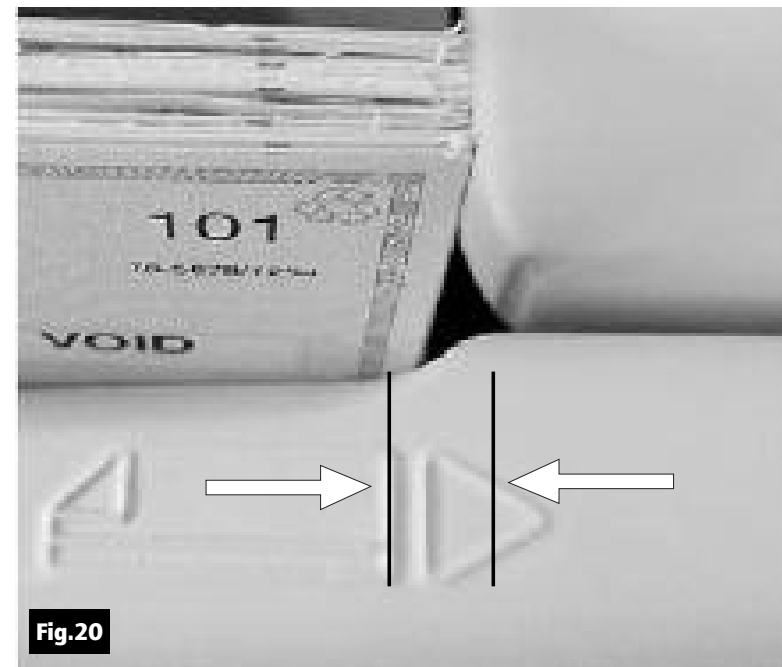
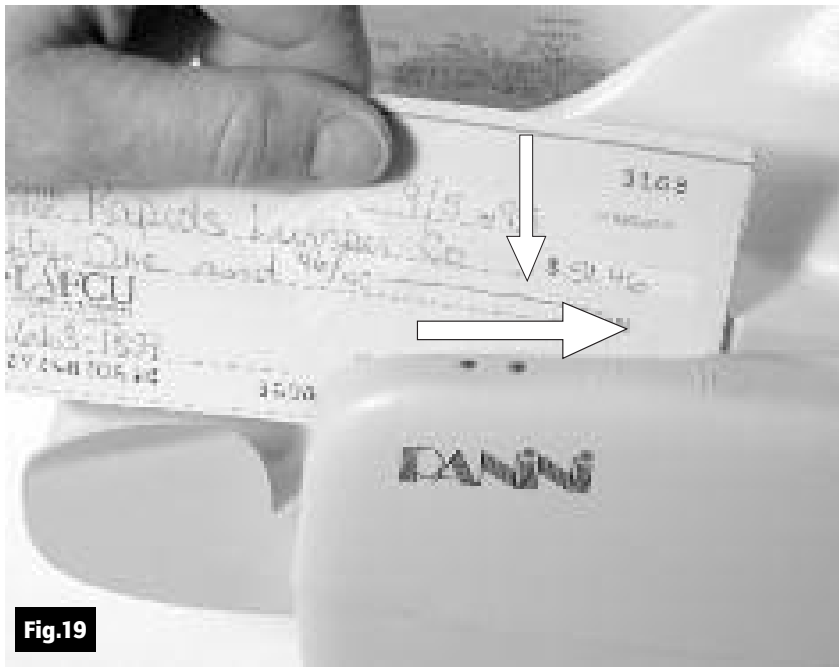

! Do not insert the checks past the rollers.



Larger batches up to 100 checks require the pressure plate be pushed back before inserting checks into the feeder.

To prevent misfeeding, do not insert more than 100 documents into the feeder. Leave at least 2 mm (1/8") between the last document and the pressure plate in the maximum backwards position. The leading edges of the documents should be aligned as described in the previous page.

Document Feeder Options

Depending on the configuration ordered, three feeder types are available:

1. Full Feeder (FF) Option:

Designed for both single document automatic insertion and up to 100 document batch processing.

2. Small Feeder (SF) Option:

Designed for both single document automatic insertion and up to 50 document batch processing.

Note: The small feeder option causes the automatic document feeding operation to stop, followed by a system warning message, after 50 consecutive documents have been processed, according to the ordered configuration. The feeder sensor must then be cleared by removing the documents from the feeder and then repositioning and restarting the application. All other features are the same as the Full Feeder.

Note: This option is reset if the feeder is emptied before the 50 document limit is met for the 50 documents limited feeder.

3. Single Document Feeder (1F) Option:

Designed to process documents one at a time with single document automatic insertion.

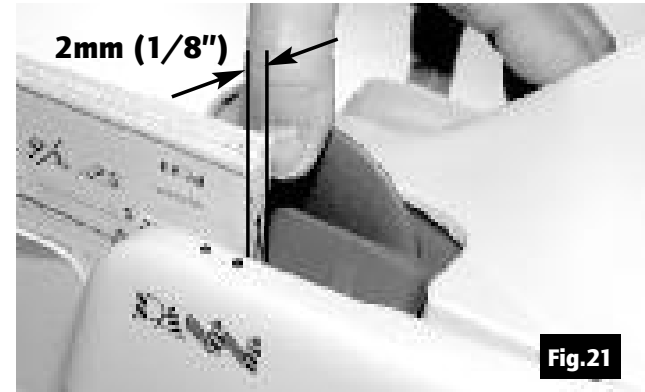

Fig.21



Advanced Solutions
for Document Processing

Vision | X

The feeder is designed so that checks can be loaded continuously, while the scanner is processing. This can be done by inserting checks behind those already present in the feeder.





Advanced Solutions
for Document Processing



Removing Documents from Pocket

Processed documents are sent to the exit pocket.

For best result, follow these recommendations:

- Remove the documents when the pocket is nearly full. Jams occur when the pocket is too full. No "pocket-full" sensor is available.
- Occasionally verify that the endorsements are clearly printed.
- Occasionally verify that the images are being properly captured and that the image quality is good.

4.3 Clearing Jams

When a jam occurs, the paper path must be cleared. To do this, first remove all the documents from the exit pocket and then free the track by pressing Eject in your application. In case of unsuccessful operation, apply the following suggestions:

1. Extract the jammed document simply by pulling it out with your fingers (see Fig.23).
2. If the document does not pull out , lift the inner cover at the point indicated by the ribbed surface as shown in Fig.24.



Fig.23

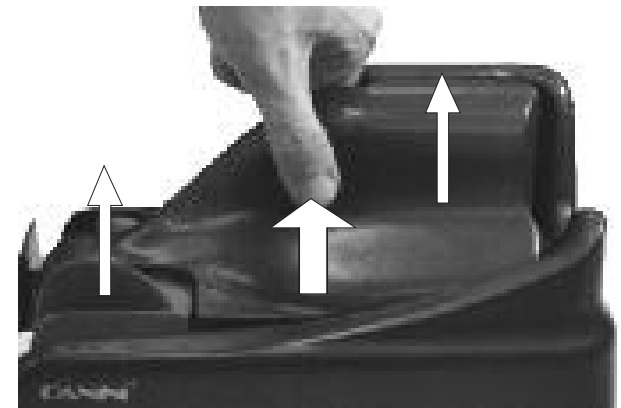
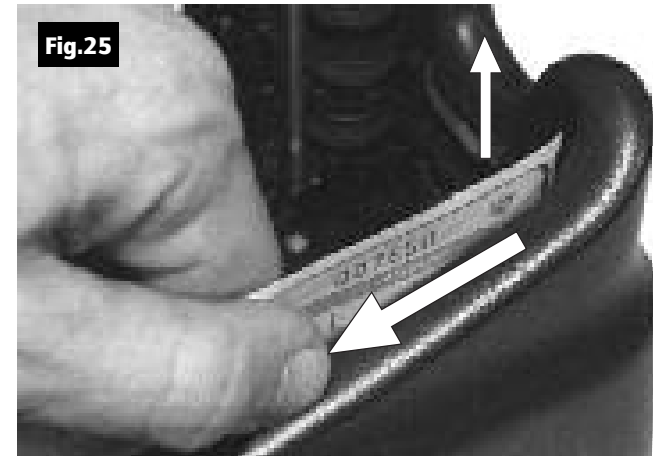

Fig.24

3. Grab the document with your fingers to remove it from the transport. (See Fig.25).



4. After the jam is removed, install the inner cover by following the instructions below:

- a. Open the pocket extension.
- b. Insert the two reference shafts in the corresponding housings found in the inner cover (See Fig.26).

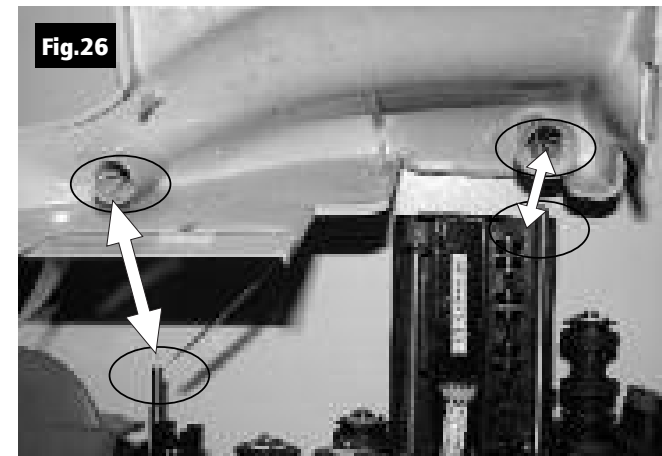

c. Push down the inner cover until it is back to its original position. Take care to ensure that the inner cover stays behind the scanner, which is indicated by a black area (see Fig.27).

The inner cover (grid) must be inserted behind the scanner (black)

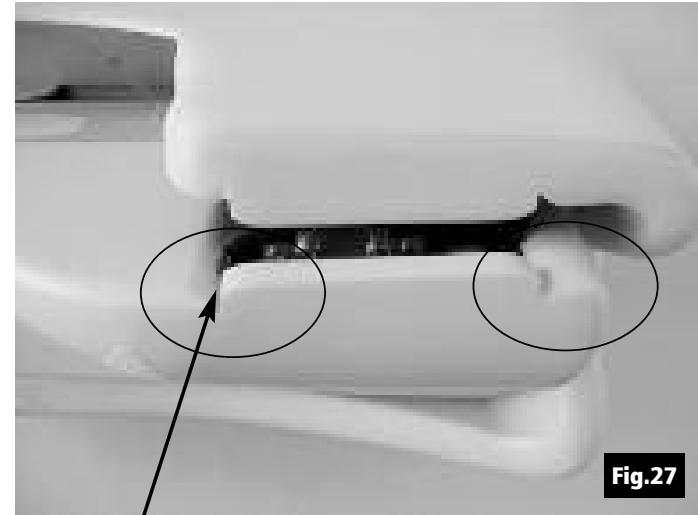
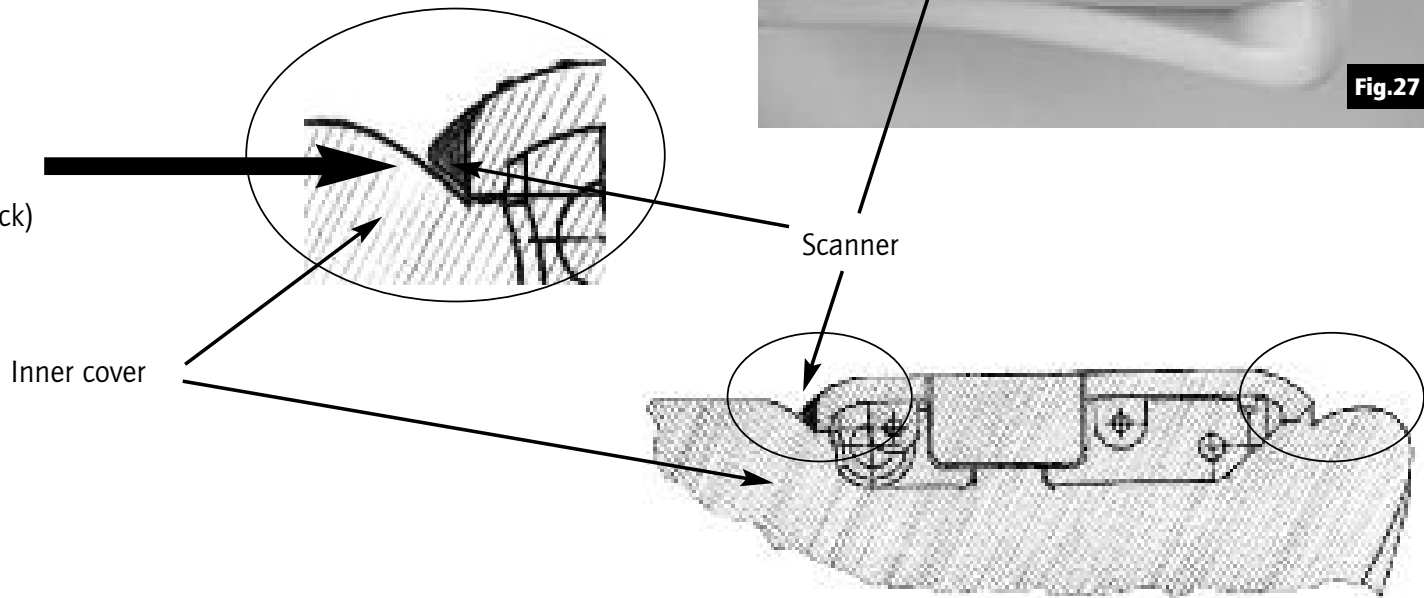

d. Check the exit pocket to ensure that the two plastic springs are aligned properly as shown in Fig.28.

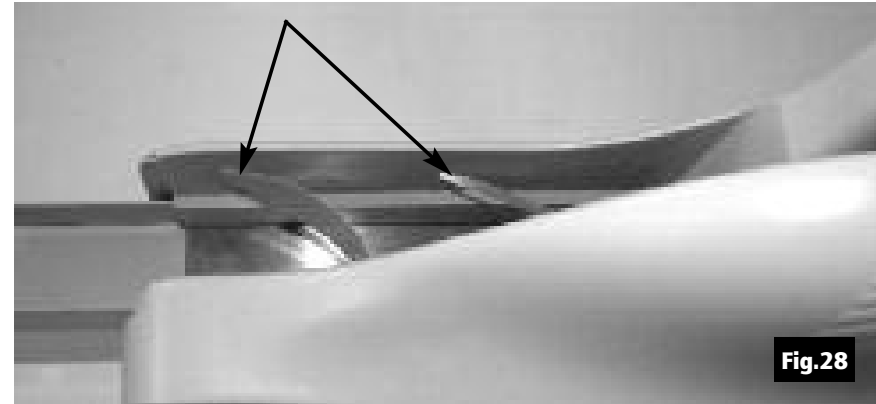

5. In the event that the outer cover has to be removed, first disconnect the USB and power cables and then lift the outer cover as shown in Fig.29.



6. To remove the "U" track wall see Fig.30.
Please follow the instructions listed in chapter 5.1.2.

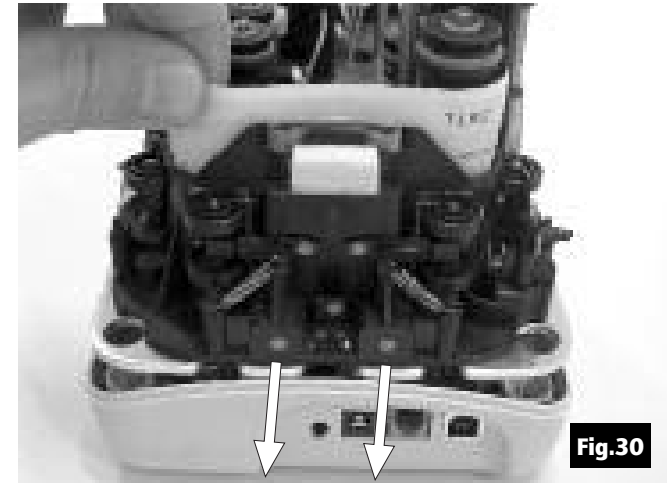

Fig.30

7. If the jam occurs in the image camera area,
it is advisable to open the front image camera
(see Fig.31) so that the document can easily be
removed.

! *Close the image camera carefully.
Don't allow the spring to snap it closed.*



Fig.31



Advanced Solutions
for Document Processing

Vision | X

8. Insert the outer cover by aligning the two shafts with the holes in the bottom cover of the unit (Fig.32). Insert the two teeth located on each side of the outer cover in the bottom cover and lock it (Fig.33 and 34).
9. Reconnect the USB and power cables.

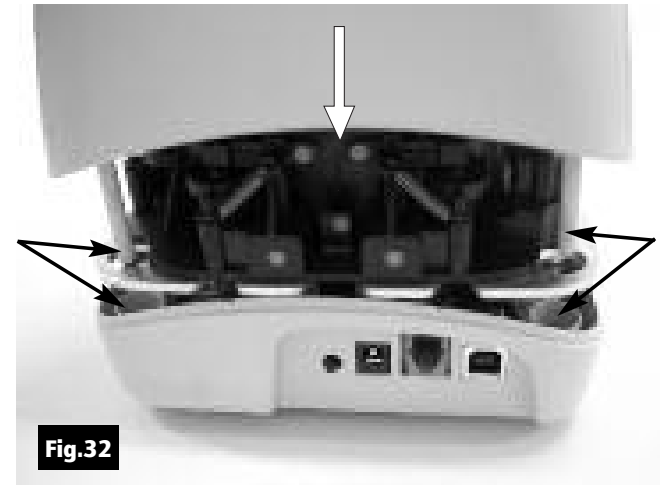

Fig.32

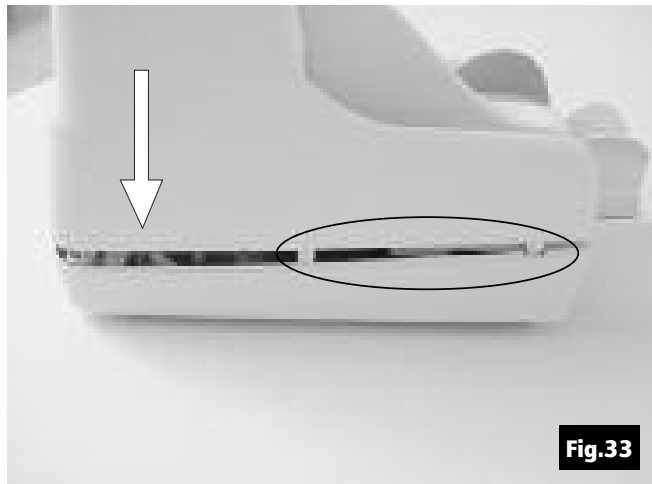

Fig.33

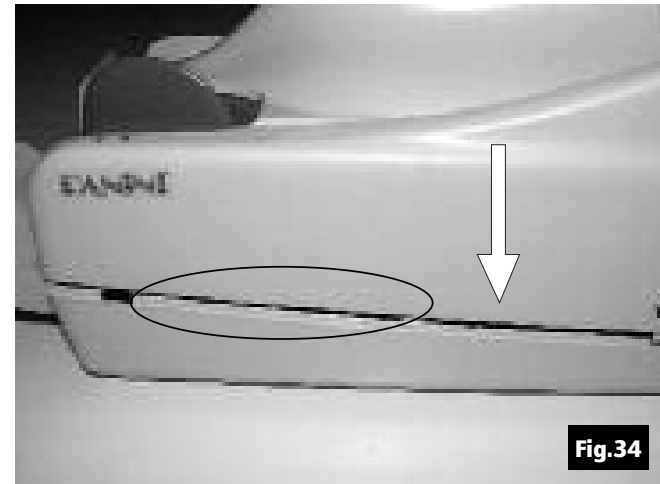

Fig.34

5. Maintenance

Warning: Before doing maintenance, remember to disconnect the USB 2 and power cables from the device.

Note: Panini recommends cleaning the Vision X weekly, or on a needed based with respect to the quantity and condition of the documents being processed.

Note: The parts accessible to the operator for cleaning or jam removal are identifiable by green stickers.

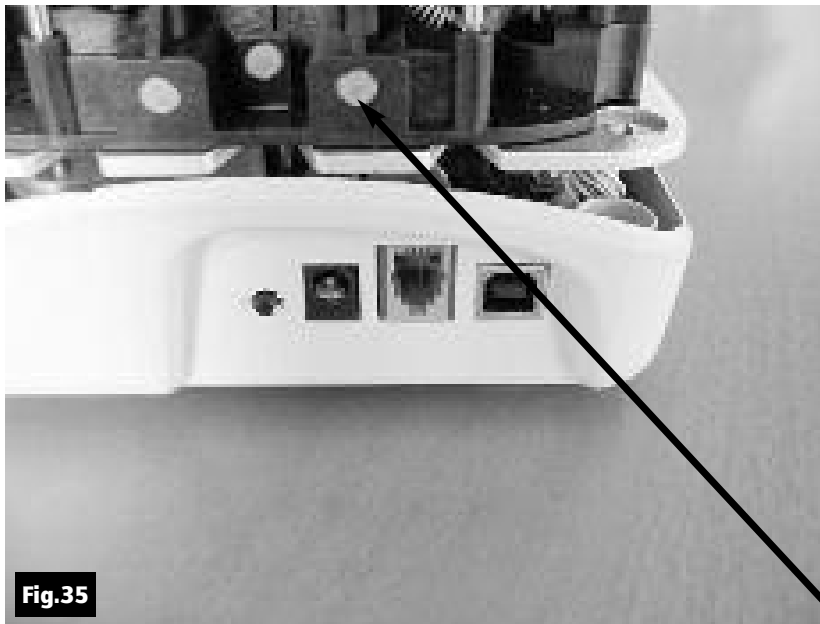

Green stickers

5.1 Cleaning the Transport

Dust, lint and small particles can get into the track area. Clean this area as follows:

1. Remove the inner and outer covers by pulling up on the covers as illustrated below.

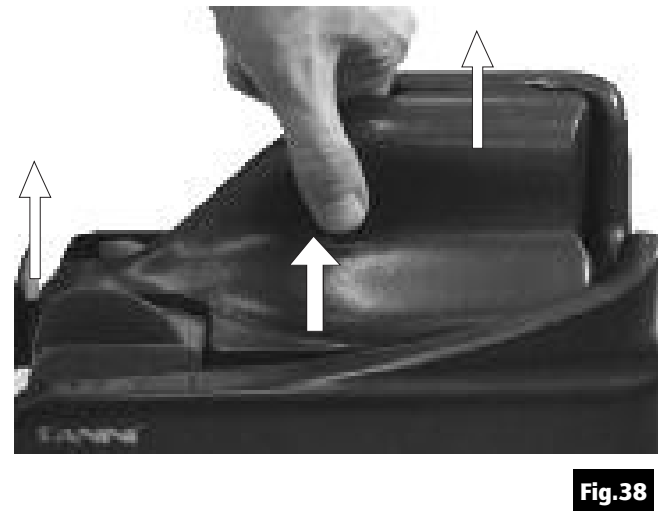
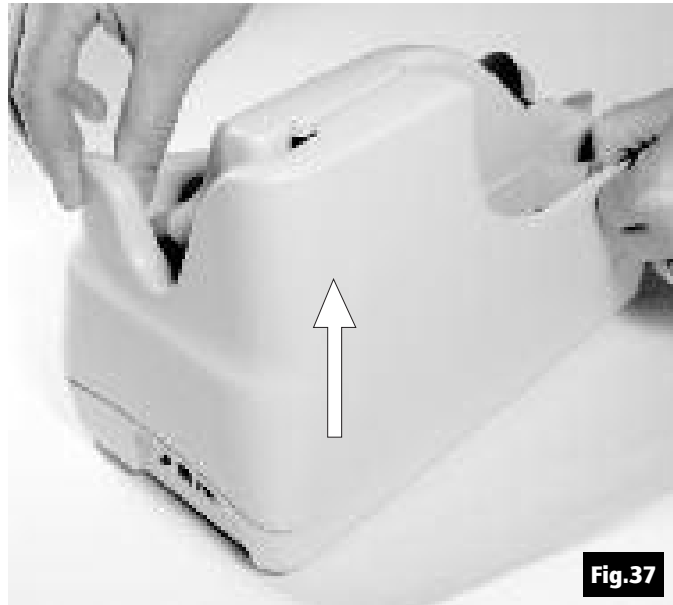

2. To remove the U-track, pull back on lever (A) away from unit (Fig.39).

The Fig.40 shows how to pull the lever and remove the U-track.

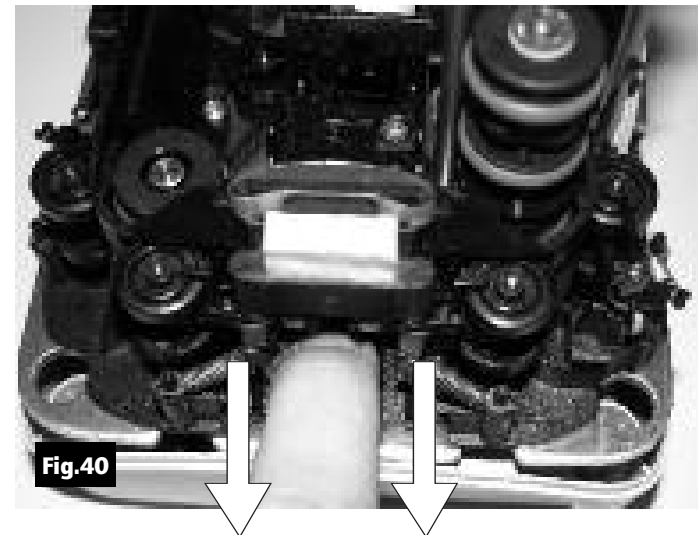
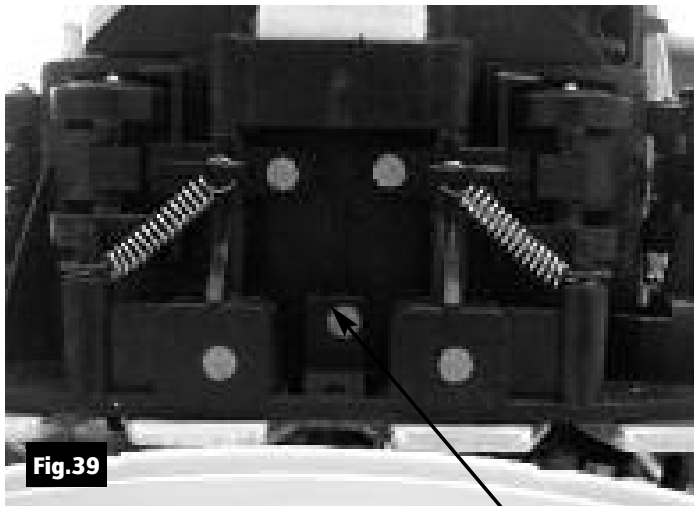

3. Inspect and clean the entire track area from beginning to end.
4. Remove staples, paper clips, rubber bands, and pieces of paper that may have accumulated during use.
5. Using a container of canned air and nozzle, spray the track area and check entrance.

6. To reinstall the U-track insert the two teeth "C" in the rail "D" (Fig.44), and align the U-track (Fig.41). Push back the U-track (Fig.45) until the lever "E" (Fig.41) locks the unit in place. Make sure that the pin "B" (Fig.43) is inserted in the receptacle "A" (Fig.42).

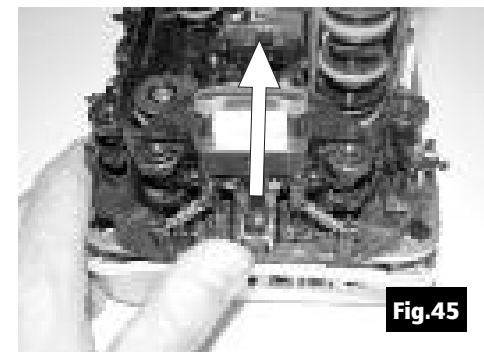
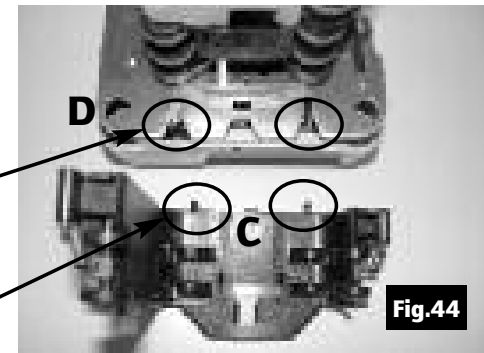
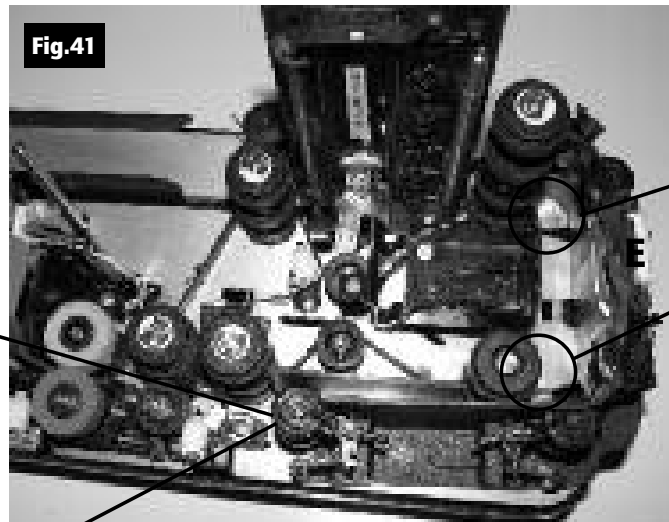
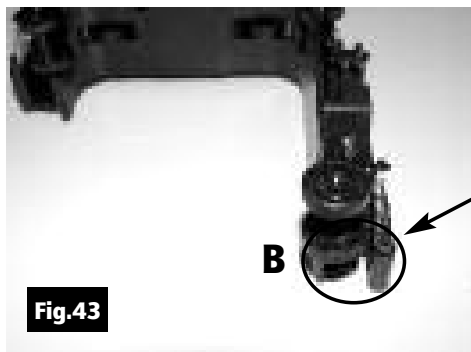
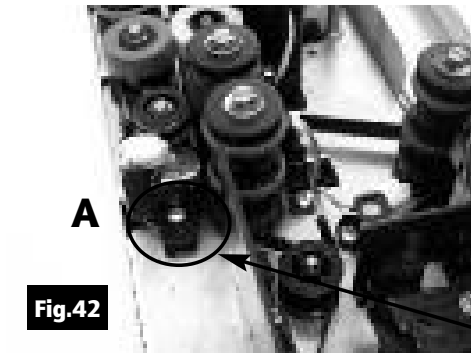

Note: If the blotting pad housing assembly. (A) comes away from the U-track, insert the low mylar spring in the lateral slots (B) and the pad housing in the reference pins (C). Gently press down until the pad housing stops on the top of the U-Track wall.

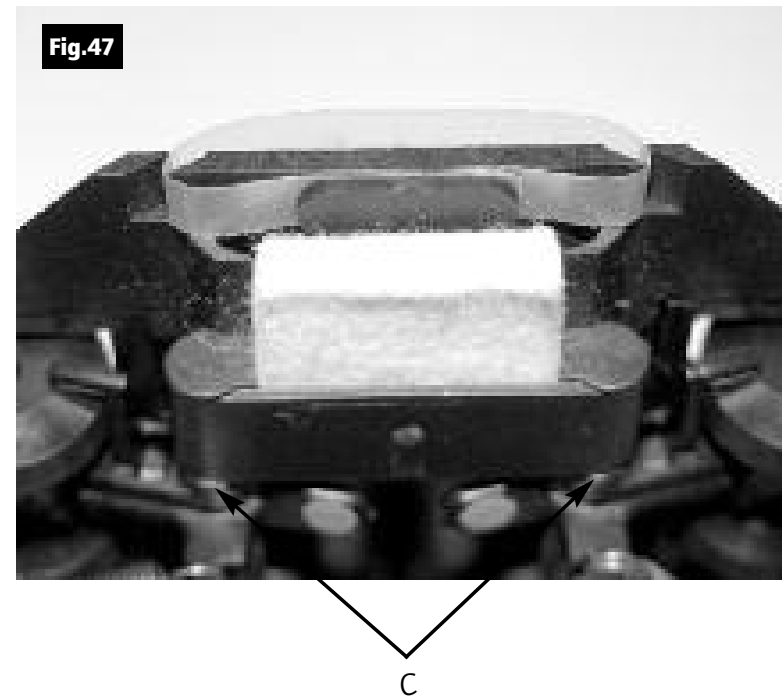
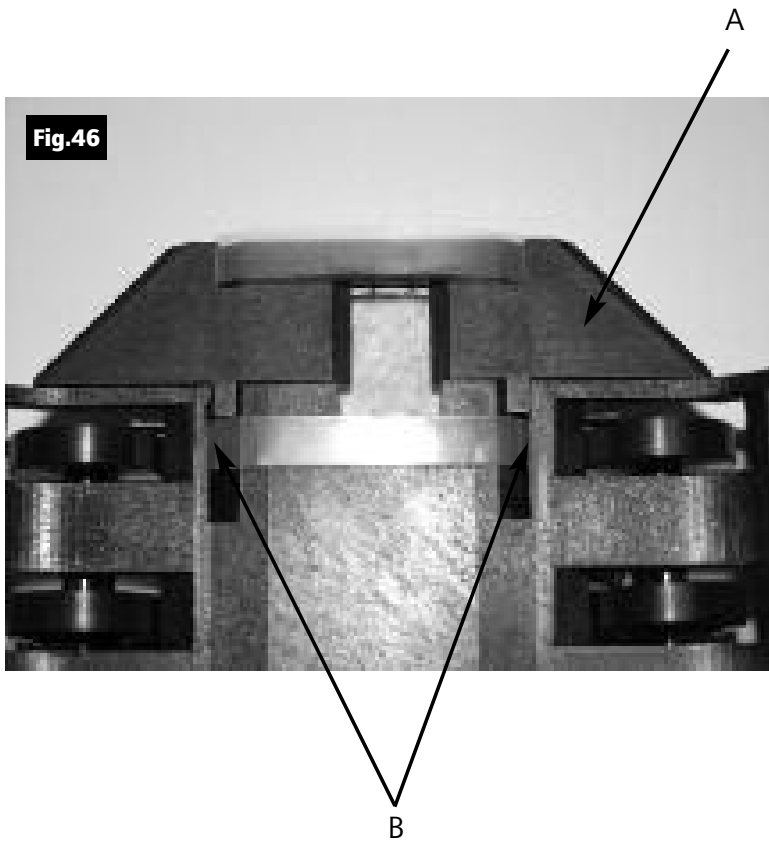

5.2 Cleaning the Contact Image Sensors

1. Gently open the front image camera (Fig.48) and remove any debris and dust.
2. Clean the Contact Image Sensors with a soft, lint-free cloth dampened with Isopropyl Alcohol or with eye glass cleaner (Fig.49).

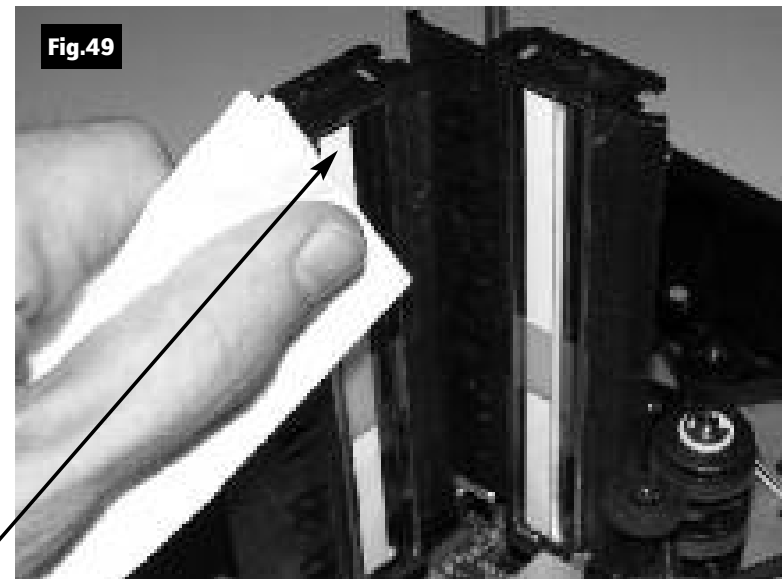
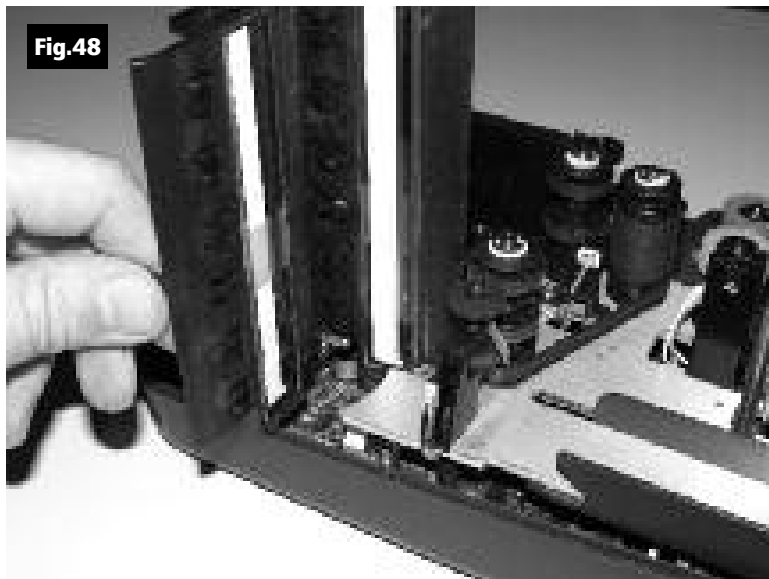

Contact Image Sensor (CIS)

5.3 Cleaning the HP C6602A Ink-Jet Cartridge (*Optional)

Fibers, such as cotton or paper, dried ink plugs or crust, or excess ink puddles on the nozzle plate can obstruct ink droplets or cause ink droplets to deflect from the desired trajectory, resulting in a degraded print quality.

When this occurs:

1. Open the inner cover.
2. Remove the print cartridge by pushing down the plastic retainer (Fig.50).
3. Dampen a clean, lint-free cloth with deionized (or distilled) water.
4. Hold the dampened cloth in contact with the nozzles for a few seconds.
5. Then gently wipe the nozzle plate in the direction of the paper movement.
Do not wipe the electrical contact area.
6. If ink remains on the nozzle plate wipe again with a clean dry lint-free cloth.
7. Reinsert the cartridge.
8. Replace the inner cover.



Remove the Ink-Jet cartridge when transporting the unit and when the unit is not used for long periods. In case the scanner is not used regularly, periodically clean the Ink-Jet nozzles with a lint-free cloth.

* If the unit was purchased without the endorser option then the unit is shipped without an ink cartridge and that one is not needed to run the device.

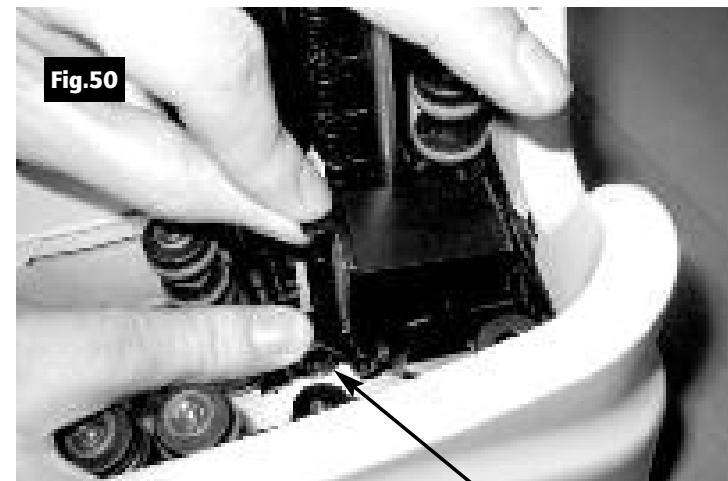

Plastic retainer

5.4 Cleaning the Photocell Detectors

The six photocells (emitter and receiver) are identified with black circles in Fig.52 below. Using a container of canned air and nozzle, spray the sensors to remove any dust. Also a dry soft cloth can be used.

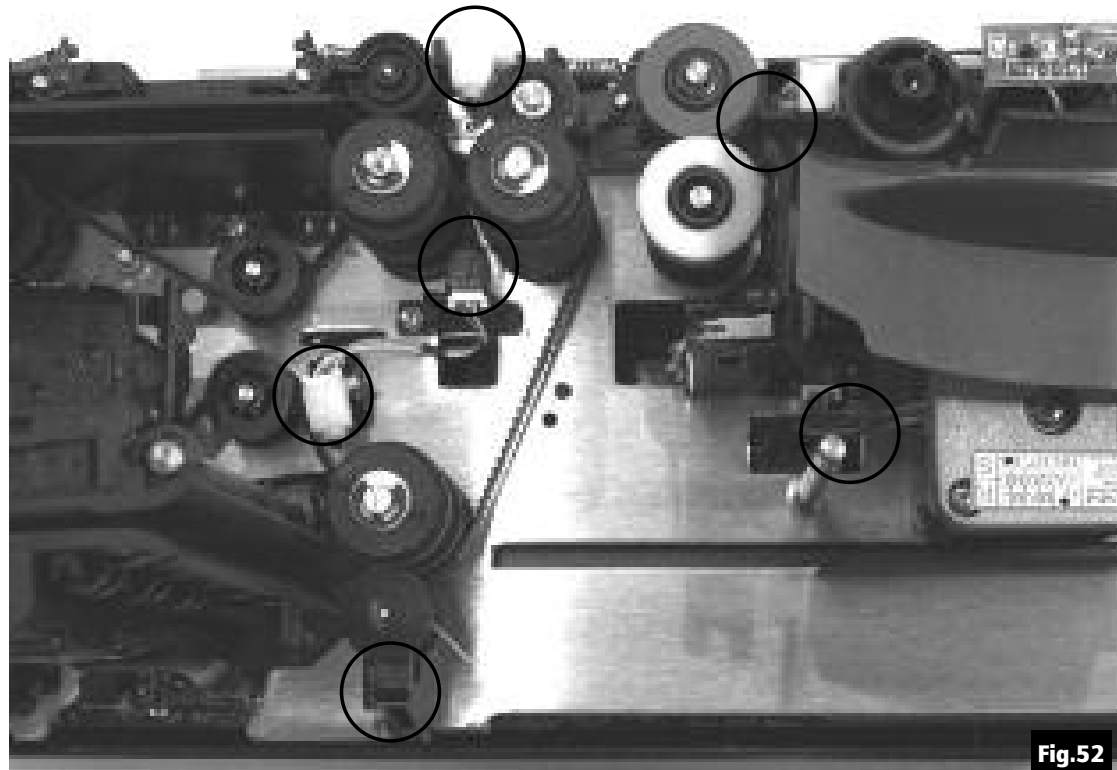
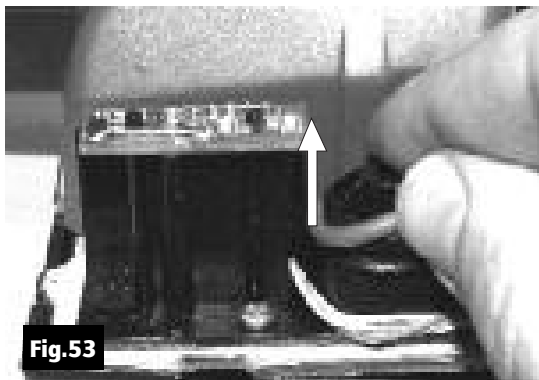

Fig.52

5.5 Replacing the Feeder and Separator Rollers

After extended use it will be necessary to replace the Feeder and Separator Roller rings due to normal wear.

1. Open the inner and outer covers.
2. Carefully lift the rings off the rollers (See the arrows in Fig.53, 54 and 55).



Feeder ring

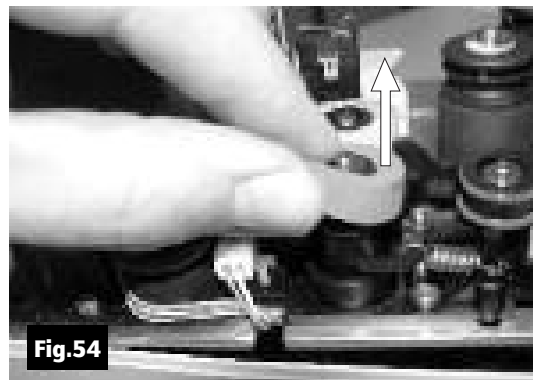

Front separator ring

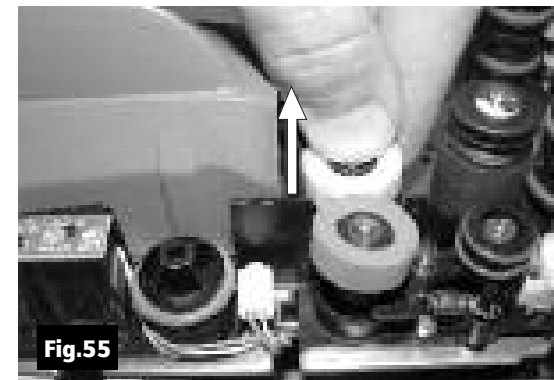

Rear separator ring

3. Install the new separator rings on the hubs by pressing down on the surface of the rings, making sure the rings are installed flat on their seats. The feeder ring must be rolled onto the black pulley.

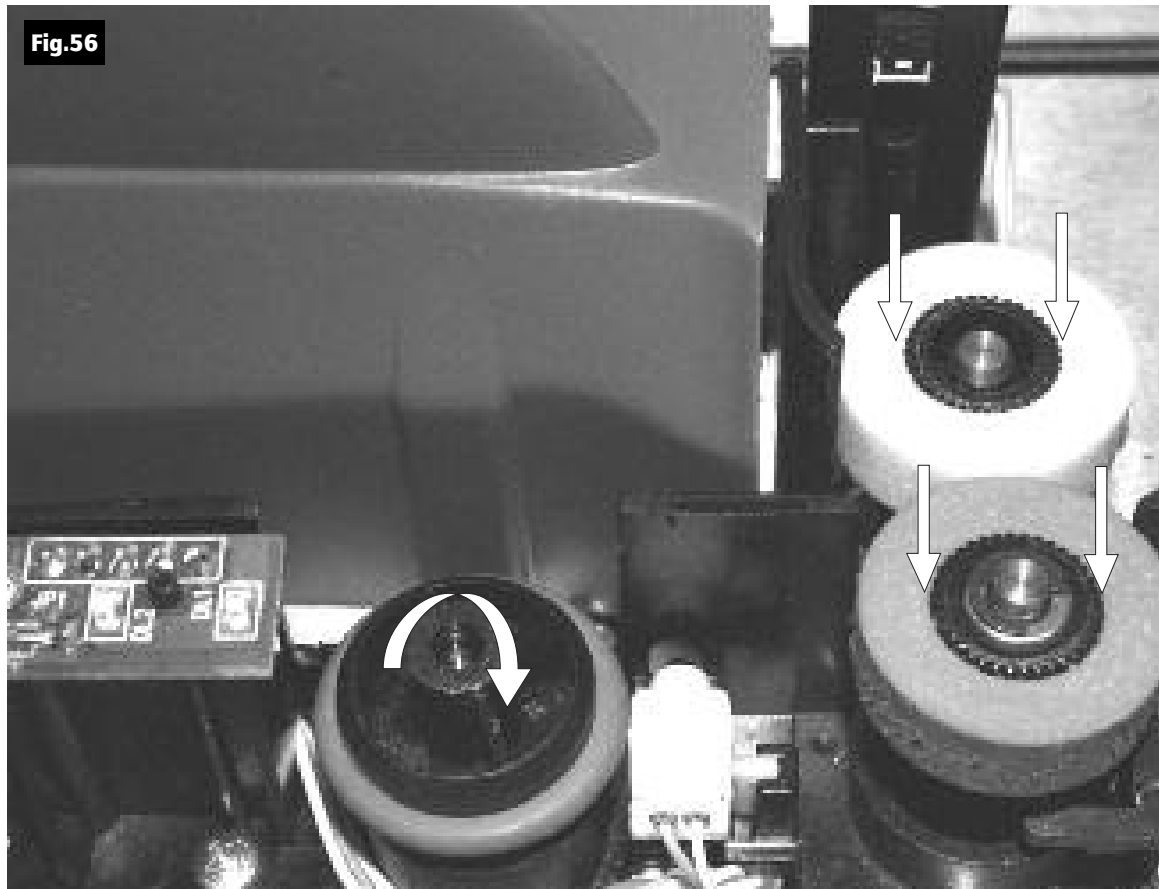

5.6 Cleaning the Reading Transport Belt

If an increase in the number of MICR (Magnetic Ink Characters Recognition) rejects is noticed, it may be necessary to clean the surface of the reading transport belt to remove extraneous magnetic ink or iron dust. Clean the external surface of the belt with a soft, lint-free cloth, dampened with Isopropyl Alcohol. Turn pulley "A" counterclockwise to move the belt in the direction of the arrow and clean the entire belt surface.

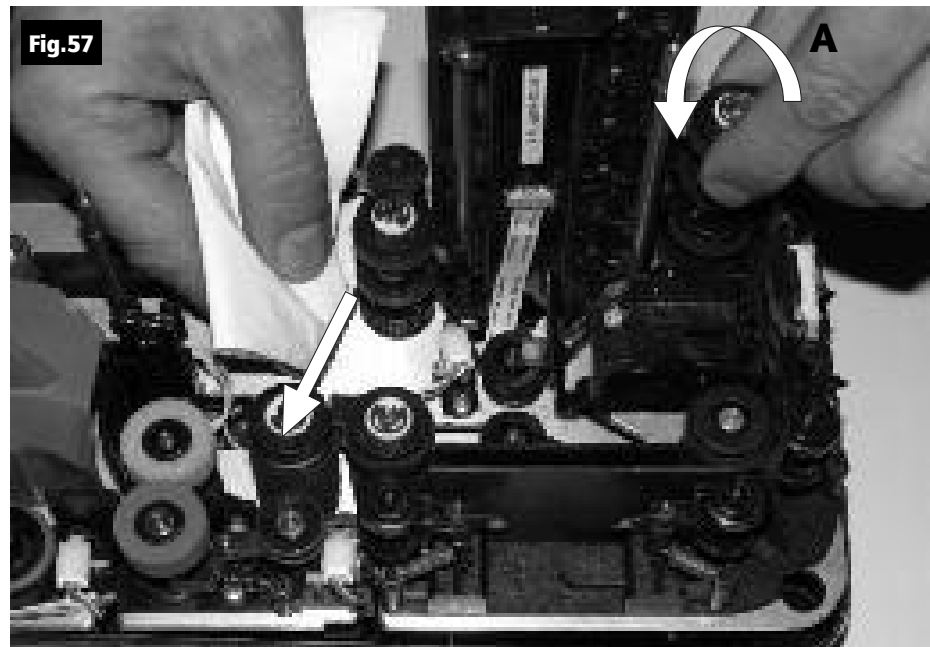

5.7 Install the External Covers

Install the inner cover following the instructions below:

1. Open the pocket extension.
2. Insert the two reference shafts in the corresponding housings found in the inner cover (Fig.58).

3. Push down on the inner cover until it stops, ensuring that the inner cover stays behind the scanner (black area) (Fig.59).

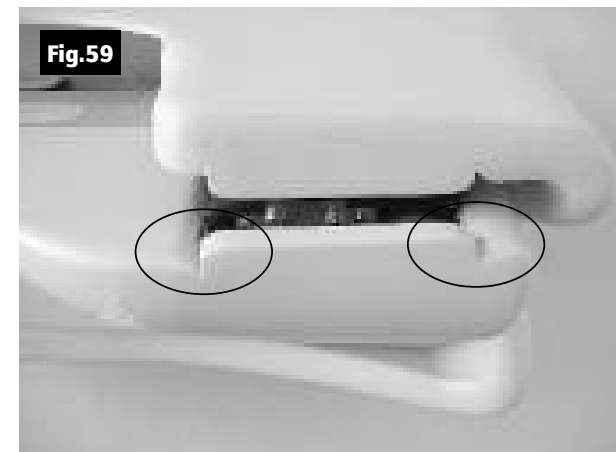
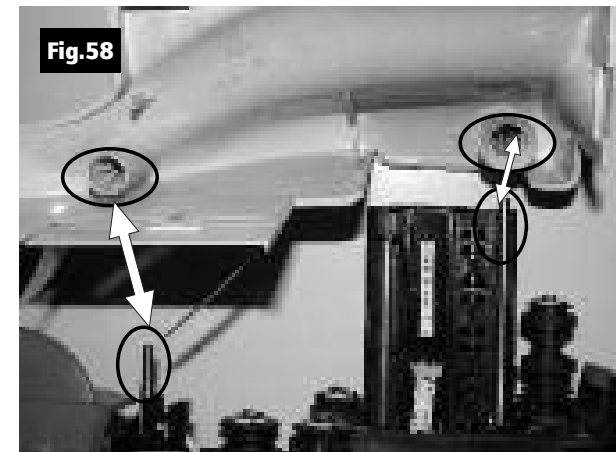

The inner cover (grid) must be inserted behind the scanner (black)

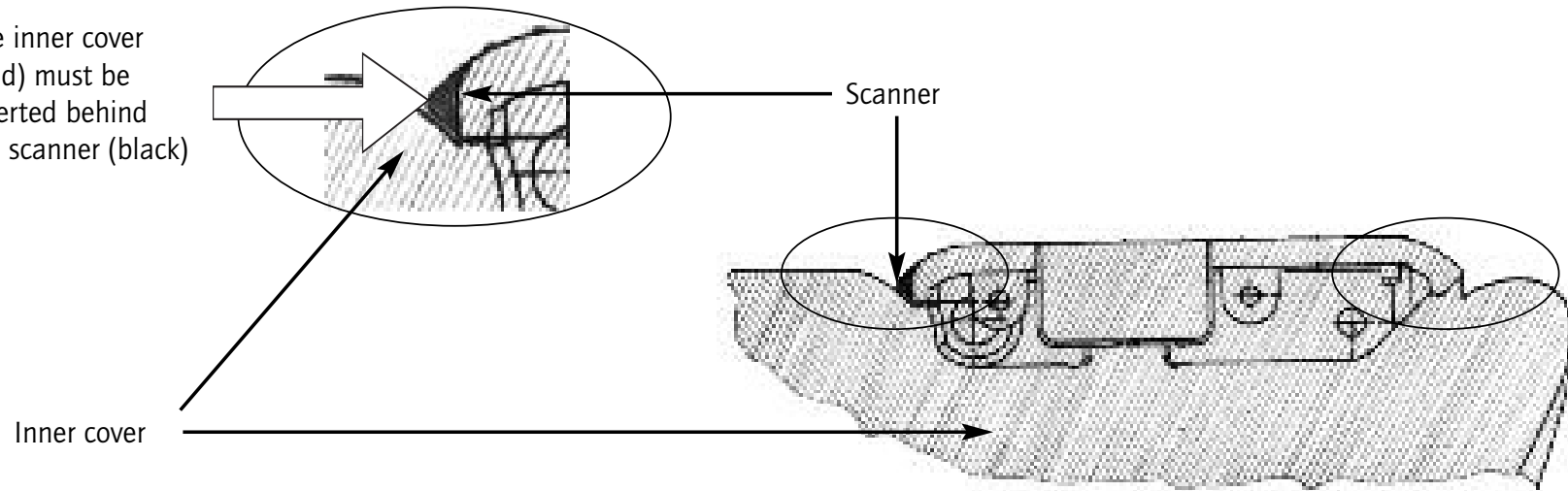

4. Check the exit pocket to ensure that the two plastic springs are properly aligned as shown in Fig.60.





Advanced Solutions
for Document Processing

Vision | X

5. Insert the outer cover by aligning the two shafts with the two holes in the bottom cover of the unit (Fig.61). Push the cover down.

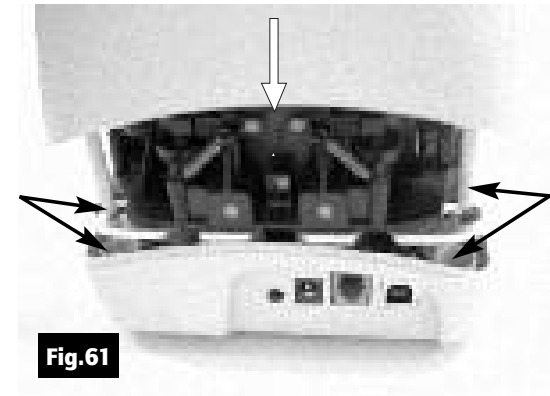

Fig.61

6. Insert the two teeth located on each side of the outer cover in the bottom cover and lock it see Fig.62 and 63.

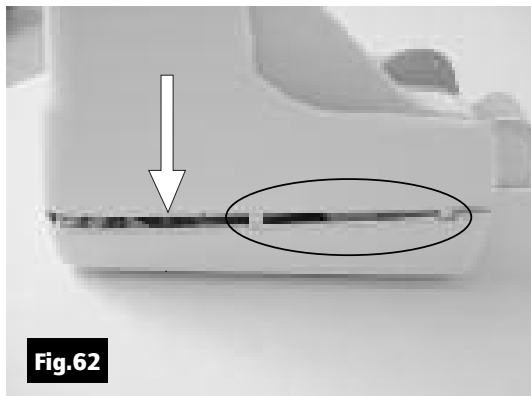

Fig.62

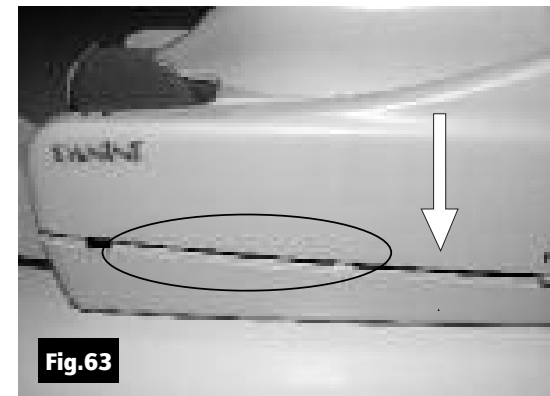

Fig.63



6. Specifications

6.1 Technical Specifications of the Panini Vision X

PERFORMANCE

3 versions (sw upgradable)
VX 50: Up to 50 DPM
VX 75: Up to 75 DPM
VX 100: Up to 100 DPM
Performance declared for 6'' checks . Final performance depends on applications and PC performance
USB2.0 interface

IMPROVED AUTOMATIC DOCUMENT FEEDER

3 versions (sw upgradable)
- single document automatic drop - 1F version
- holding up to 50 documents - SF version
- holding up to 100 documents - FF version
Double feed detection with infrared (std) and ultra sonic technologies(future HW option)
Auto-tuning separator rollers designed to process varied thickness of documents and to compensate wear

INKJET PRINTER

2 versions (sw upgradable)
Rear Ink-jet Printer (IJ version) and No ink jet (NJ version, sw upgradable)
Printing capability: Single line, Alphanumeric characters, all MS Windows fonts
Reg CC Compliant
Printed information captured by the image
Intelligent printing, image and MICR driven
Automatic cartridge presence detection and empty cartridge alert

TOTAL COMPATIBILITY AND SCALABILITY

Total backward compatibility for software API > release 2.24
Full version scalability (for sw options) throughout the range, via software upgrade

POCKETS

A single exit pocket capable of holding up to 100 documents

WORKSPACE

Extremely compact footprint - Ideal for teller, back office and corporate installations

DOCUMENTS SPECIFICATIONS

Height: Min: 54 mm (2.12'') - Max: 106 mm (4.17'')
Length: Min: 80 mm (3.14'') - Max 235 mm (9.25'')
Weight: Min: 60 gr/m² (16#) - Max: 120 gr/m² (32#)

INTERFACE

USB2.0 port/Backward compatible with USB 1.1
RS232 Port for external device connection. (SW/FW developments on request.)



MAGNETIC READER

E13B/CMC7/Automatic
New Panini MICR Plus® exclusive technology with OCR assist feature
Superior MICR recognition and management

IMAGE CAPTURE

Scanning: Next Generation Contact Image Sensor (CIS) technology (front and rear)
Image format: Bitmap in B/W, 256 shades of gray, Infrared, Color (Fast and True) and drop out mode. TIFF, JPEG and Group IV compression
Image Quality Assurance sw (IQA) available as sw option
Image resolution: 100, 200 or enhanced 300 dpi
Advanced Dynamic Thresholding
Superior auto calibrated image quality
Dual Image: 4 images in one document pass

SOFTWARE TOOLS

Panini Vision API control running on:
Windows 2000 S.P. 3, XP S.P. 1, Windows Vista with USB 2.0 or USB 1.1
ICR Vision function for image snippet definition and download
Easy integration of ICR/Barcode/OCR recognition technology

ADDITIONAL OPTIONS

HW : 3 Tracks Magnetic BADGE READER (future option)
HW: External dongle for temporary and device independent upgrades
SW: OCR Recognition: OCR-A, OCR-B recognition engine
SW: Barcode Recognition: Code 39, Interleaved 2/5, EAN8, EAN13, UPCA, UPCE, Code 128
SW: Bi-dimensional barcode (pdf)

**APPLICATION PC
MINIMUM REQUIREMENTS**

V X 50, V X 75: Intel Pentium IV, 1.2 GHz, 512 Megabytes Ram
V X 100: Intel Pentium IV, 2 GHz, 512 Megabytes Ram

DIAGNOSTIC FEATURES

On board Diagnostics: tests the functionality of the scanner
Power-on Self Testing: Automatic self testing and photocells calibration when powering the unit

MAINTENANCE

Maximum accessibility to every component to minimize MTTR
Total access to scanner and track area
Firmware upgradeable via PC

POWER SUPPLY INPUT VOLTAGE

Autosensing from 100 to 240 Vac, 50 to 60 Hz

DEVICE INPUT VOLTAGE

30 VDC

OPERATING CONDITIONS

Temperature: 15 ÷ 35°C
Humidity: 20 ÷ 80% R.H. Non-Condensing

DIMENSIONS and WEIGHT

Height	Width	Length	Weight
175 mm (6.88")	138 mm (5.43")	264 mm (10.39")	2.5 Kg (5.73#)

Specifications subject to change without previous notice.



6.2 Technical Specification of the PC

<p>Panini Vision API running on: Windows 2000 SP3 or Windows XP SP1 or higher with USB2.0 or USB1.1 port Windows NT 4.0 SP6 with USB1.1</p>
<p>50 dpm and 75 dpm Models</p>
<p><i>Application PC minimum requirements</i> Intel Pentium IV, 1.2 GHz, 512 Megabytes Ram</p>
<p>100 dpm Models</p>
<p><i>Application PC minimum requirements</i> Intel Pentium IV, 2 GHz, 512 Megabytes Ram</p>

7. Vision X SD Addendum

This addendum provides specific product details related to the Vision X SD model. This information highlights product characteristics that vary from the information in the Operator Manual.

Vision X SD Packaging List

** Replaces section 2.1

The package includes:

1. Operator Manual
2. Accessories box (*)
3. Vision X scanner unit
4. Power Cable

(*) The accessories box contains:

- Feeder Extension
- Extension plate
- Ink-Jet Cartridge HP C6602A
- USB 2 Cable
- Power Supply
- Ink-Jet Plastic Lever (adapter for HP 51604 cartridge)
Cartridge not included with No Ink Jet (NJ) versions

Document Support Installation

** Replaces section 3.1

The installation procedure for inserting the document feeder extension on a SD machine varies slightly as the Document Pressure Plate has a fixed position and can not be pushed backwards. The Feeder Extension is simply inserted into the available slot. Installation is correct if the Feeder Extension is at the same level of the entrance of the scanner platform.

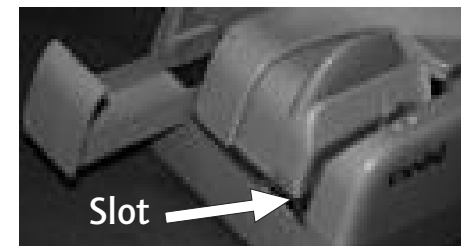



Advanced Solutions
for Document Processing



How to Prepare and Load Checks

** Adjustment to section 4.2

The SD scanner unit is designed for single document processing exclusively. All references to preparing and processing batches of multiple items in this section is not relevant to the SD version of the Vision X. Inserting multiple items into the feeder of a SD scanner will cause multiple documents to be fed or document jams to occur.

Replacing the Feeder and Separator Rollers

** Adjustment to section 5.5

Please note that the Vision X SD machine is not furnished with front and rear separator rollers. The addition of which is not needed when processing one item at a time. As such, the instructions for replacing these rings are irrelevant with reference to the SD scanner unit.



8. Vision X AGP Addendum

This addendum provides specific product details related to the Vision X AGP model. This information highlights product characteristics that vary from the information in the Operator Manual.

AGP Packaging List

** Replaces section 2.1

The Panini Vision X AGP package includes:

1. Operator Manual
2. Accessories box (*)
3. Panini Vision X AGP scanner unit
4. Power Cable
5. Ink-Jet Cartridge

(*) The accessories box contains:

- Feeder Extension & Extension plate
- USB 2 Cable
- Power Supply
- Panini cleaning cloth (Panini P/N: GS-00020-00)
Cartridge not included with No Ink Jet (NJ) versions

AGP Ink-Jet Cartridge Use

Use only one of the following Panini recommended cartridges.

Cartridge	Panini Part Number	Usage
HP Q2344A (Black 1918 Dye) *	CA-00140-00	Best for high usage
Universal Black 7482	CA-00165-00	Best for high and low usage

* Note: Frequent cleaning of the nozzle head may be required on HP Q2344A cartridges when processing with long intervals between batches of endorsed documents.

Ink-Jet Cartridge Installation

** Replaces section 3.5 and 3.6

The following steps indicate how to install the Vision X AGP ink-jet cartridge.

- Remove the new print cartridge from its package, and gently remove the transparent tape covering the ink nozzles, being careful not to touch the ink nozzles and electrical contacts.
- Remove Vision X inner cover (see section 4.3)
- Push the new cartridge down firmly into its cradle slot, and close the rear cradle lever.
- Insert the inner cover

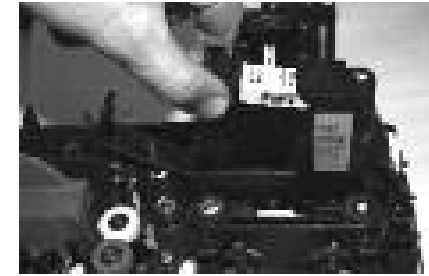

Cleaning the Contact Image Sensors

** Addition to section 5.2

In addition to following the basic cleaning instructions provided in section 5.2 of the Operator Manual, Panini recommends that you occasionally inspect the images for the presence of any streaking due to residual ink on the Contact Image Sensors (CIS) glass. If so, use the Panini cleaning cloth (Panini P/N: GS-00020-00) to clean the CIS surface.

Cleaning the Ink-Jet Cartridge

** Replaces section 5.3

Fibers, such as cotton or paper, dried ink plugs or crust, or excess ink puddles on the nozzle plate can obstruct ink droplets or cause ink droplets to deflect from the desired trajectory, resulting in a degraded print quality.



Advanced Solutions
for Document Processing

Vision | X

- Open the inner cover
- Open the rear cradle lever and remove the print cartridge
- Using a slightly dampened (de-ionized water is best) lint free cloth gently wipe the nozzle head in an upward vertical direction. Do not apply excessive force, as this could scratch the nozzle surface
- Reinsert the print cartridge and inner cover

Note: If the print cartridge sits inactive for a period of time, ink may dry clogging the nozzles. As a result white streaks will be visible in the printed text or graphic on the document. Printing alone may not remove ink clogs. Follow the steps above to properly clean the nozzle. If print quality does not improve, gently shake the cartridge with the nozzle head towards the cleaning cloth, causing a slight expulsion of ink on the cloth. Gently wipe the nozzle head in an upward vertical direction. The Ink being pulled from the cartridge will flush the nozzles out, then print a few lines of text or graphics.



9. Vision X P Addendum

This addendum provides specific product details related to the Vision X P model. This information highlights product characteristics that vary from the information in the Operator Manual.

External Parts Description

** Replaces section 2.2

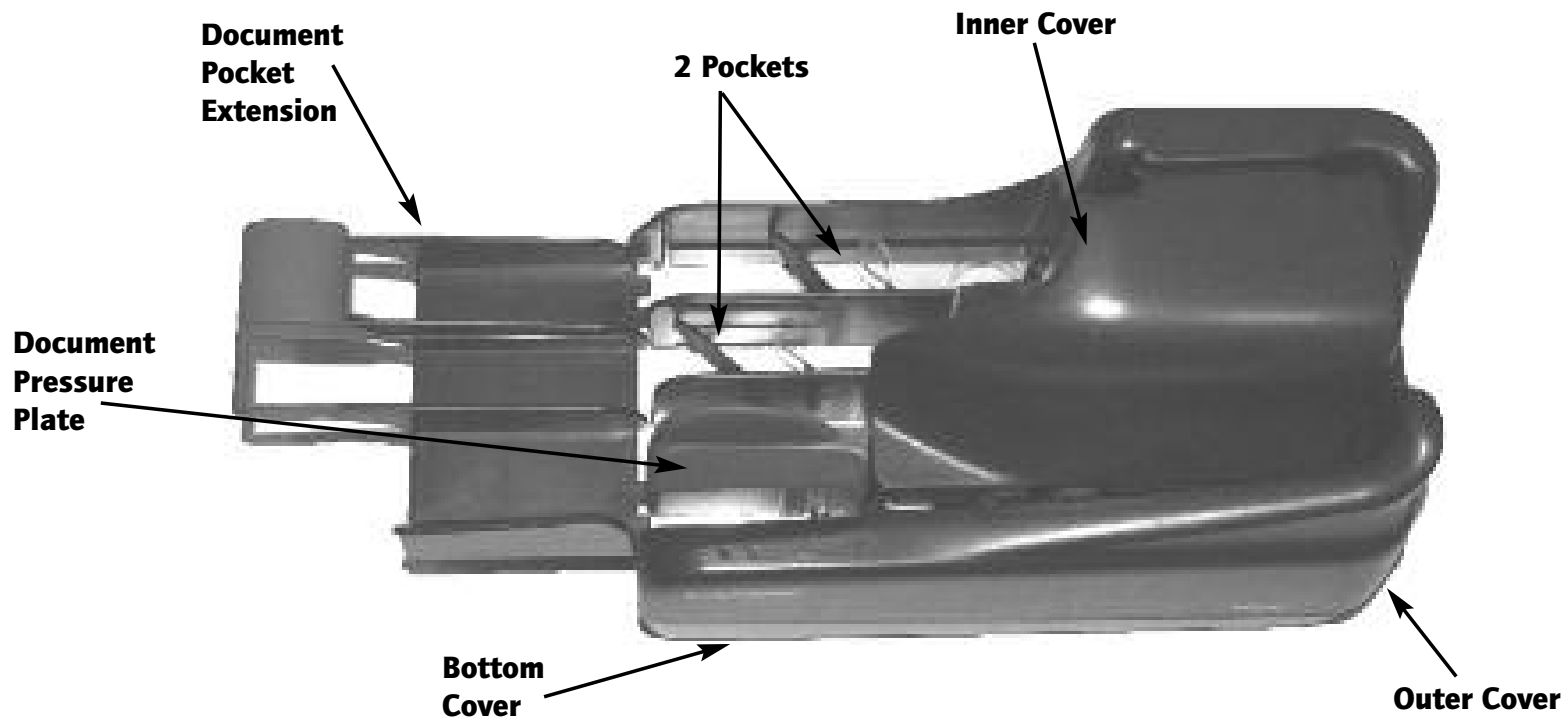



Internal Parts Description

** Replaces section 2.3

1. Document Pressure Plate
2. LED board
3. Feeder Roller
4. Feeder Sensor
5. Separator Roller
6. Rear Separator Roller
7. Pre-magnetization Head
8. Synchronization Sensor
9. MICR Reading Head
10. "U" Track Wall
11. Transport Rollers
12. Ink-Jet Cartridge Cradle
13. Front Image Camera
14. Rear Image Camera
15. Pocket sensor
16. Transport Belt
17. Interlock Board
18. Feeder Motor
19. Document Alignment Mylar
20. Full Pocket Sensor

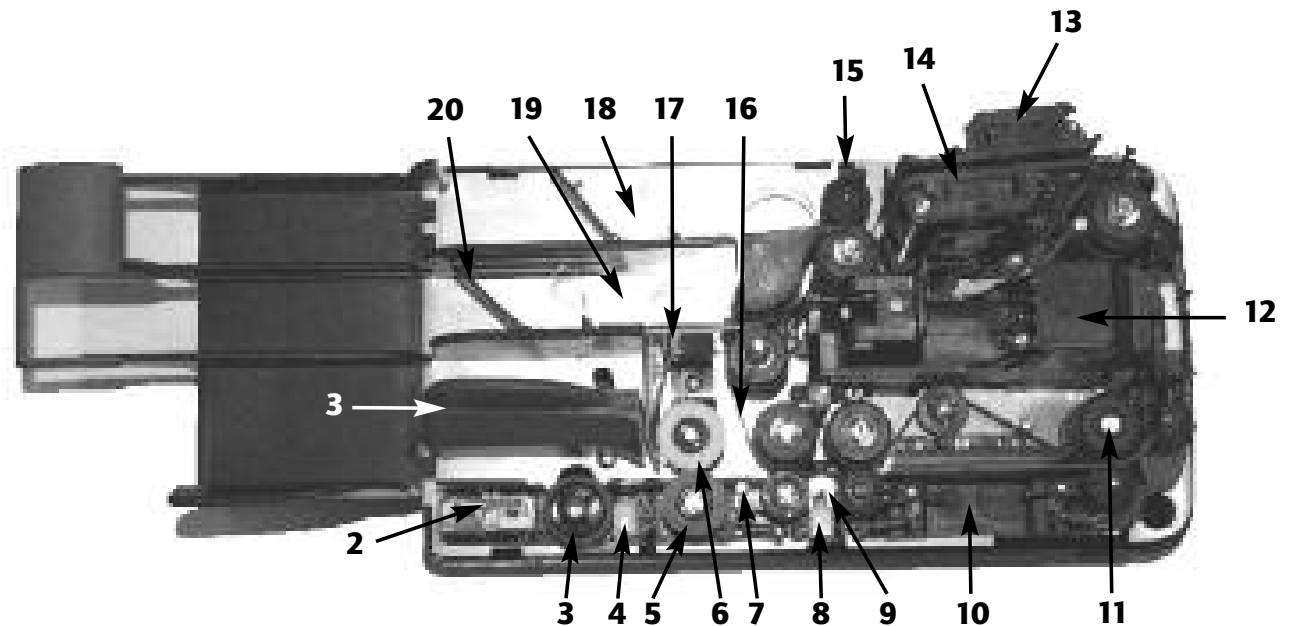

Document Support Installation / Pocket Length Adjustment

** Replaces section 3.1

Insert the Document Pocket Extension in the slot uncovered by pushing back the Document Pressure Plate and the corresponding slots in the first document pocket. Installation is correct if the Document Pocket Extension is at the same level of the scanner base plate.

Adjust the pocket length by inserting the longest document that will be processed in the pocket. Move the pocket extension plate left or right until a space of 5 mm (1/4") is available between the leading edge of the document and the end of the pocket extension. The pocket extension plate will provide support for both machines pockets.

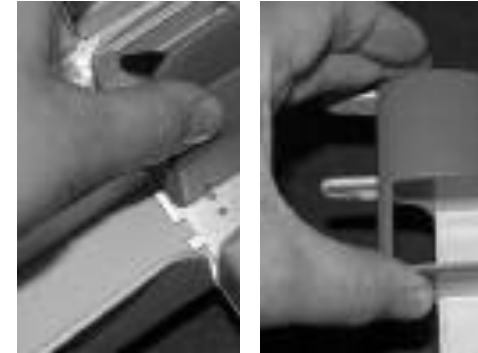

Cleaning the Contact Image Sensors

** Addition to section 5.2

In addition to following the basic cleaning instructions provided in section 5.2 of the Operator Manual, Panini recommends that you occasionally inspect the images for the presence of any streaking due to residual ink on the Contact Image Sensors (CIS) glass. If so, use the Panini cleaning cloth (Panini P/N: GS-00020-00) to clean the CIS surface.



Technical Specifications of the Panini Vision X P

Vision X P Technical Specifications	
<p>PERFORMANCE</p> <p>3 versions (sw upgradable) VX P 50: Up to 50 DPM VX P 75: Up to 75 DPM VX P 100: Up to 100 DPM Performance declared for 6" checks. Final performance depends on applications and PC performance USB2.0 interface</p>	<p>ADDITIONAL OPTIONS</p> <p>HW: 3 Tracks Magnetic BADGE READER (future option) HW: External dongle for temporary and device independent upgrades SW: OCR Recognition: OCR-A, OCR-B SW: Barcode Recognition: Code 39, Interleaved 2/5, EAN8, EAN13, UPCA, UPCE, Code 128 SW: Bi-dimensional barcode (pdf)</p>
<p>IMPROVED AUTOMATIC DOCUMENT FEEDER</p> <p>2 versions (sw upgradable):</p> <ul style="list-style-type: none"> • Holding up to 50 documents – SF version • Holding up to 120 documents – FF version <p>Double feed detection with infrared (std) and ultrasonic technologies (future HW option). Auto-tuning separator rollers designed to process varied thickness of documents and to compensate wear</p>	<p>POCKETS</p> <p>2 versions (based on the same hardware platform) :</p> <ul style="list-style-type: none"> • 1P: one exit pocket capable of holding 100 documents • 2P: two exit pockets capable of holding 100 documents each. <p>Flexible Sorting Options, based on MICR and/or image Full pocket sensor for both versions</p>
<p>MAINTENANCE</p> <p>Maximum accessibility to every component to minimize MTTR Total access to scanner and track area Firmware upgradeable via PC</p>	<p>MAGNETIC READER</p> <p>E13B/CMC7/Automatic New Panini MICR Plus® exclusive technology with OCR assist feature Superior MICR recognition and management MICR based sorting</p>
<p>DOCUMENTS SPECIFICATIONS</p> <p>Height: Min: 54 mm (2.12") – Max: 106 mm (4.17") Length: Min: 80 mm (3.14") – Max 235 mm (9.25") Weight: Min: 60 gr/m2 (16#) – Max: 120 gr/m2 (32#)</p>	<p>SOFTWARE TOOLS</p> <p>Panini Vision API control running on: Windows 2000 S.P. 3, XP, Windows Vista with USB 2.0 or USB 1.1 ICR Vision function for image snippet definition and download Easy integration of ICR/Barcode/OCR recognition technology</p>



<p>INKJET PRINTER</p> <p>Rear Ink-jet AGP (advanced Graphic Printer) Printing capability, two versions:</p> <ul style="list-style-type: none"> • AGP 1: one line text/graph in any vertical position • AGP 2: two lines text/graph in any vertical position • AGP 4: four lines text/graph for full 1/2" height <p>Alphanumeric characters: all MS Windows fonts Reg CC Compliant Printed information captured by image Intelligent printing based on MICR or image on a defined printing area Automatic cartridge presence detection and empty cartridge alert</p>	<p>IMAGE CAPTURE</p> <p>Scanning: Contact Image Sensor (CIS) technology (front and rear) Image format: Bitmap in B/W, 256 shades of gray, Infrared, Color (Fast and True) and drop out mode. TIFF, JPEG and Group IV compression Image Quality Assurance sw (IQA) available as sw option Image resolution: 100, 200 or enhanced 300 dpi Advanced dynamic thresholding Superior auto calibrated image quality Dual Image: 4 images in one document pass Front/rear image based sorting</p>
<p>INTERFACE</p> <p>USB2.0 port/Backward compatible with USB 1.1 RS232 Port for external device connection.</p>	<p>TOTAL COMPATIBILITY AND SCALABILITY</p> <p>Total backward compatibility for software API > release 2.24 Full version scalability (for sw options) throughout the range, via software upgrade</p>
<p>APPLICATION PC MINIMUM REQUIREMENTS</p> <p>V X P 50, V X P 75: Intel Pentium IV, 1.2 GHz, 512 Megabytes Ram V X P 100: Intel Pentium IV, 2 GHz, 512 Megabytes Ram</p>	<p>WORKSPAC</p> <p>Extremely compact footprint – Ideal for teller, back office and corporate installations</p>
<p>DIAGNOSTIC FEATURES</p> <p>On board Diagnostics: tests the functionality of the scanner Power-on Self Testing: Automatic self testing and photocells calibration when powering the unit</p>	<p>DIMENSIONS AND WEIGHT</p> <p>Height: 175 mm (6.88") Width: 138 mm (5.43") Length: 264 mm (10.39") Weight: 2.6 Kg (5.73#)</p>
<p>OPERATING CONDITIONS</p> <p>Temperature: 15 ÷ 35°C Humidity: 20 ÷ 80% R.H. Non-Condensing</p>	<p>POWER SUPPLY INPUT VOLTAGE</p> <p>Autosensing from 100 to 240 Vac, 50 to 60 Hz</p>
<p>DEVICE INPUT VOLTAGE</p> <p>30 VDC</p>	

10. **Vorschriftsmäßige Entsorgung von Elektro- und Elektronikaltgeräten (WEEE)**

FÜR LÄNDER DER EUROPÄISCHEN UNION (EU)

Die EU-Kommission hat bestimmt, dass elektrische und elektronische Geräte, die heute auf dem Markt angeboten werden, Bauteile und Komponenten enthalten, die wiederverwertet werden und somit dazu beitragen können, die in Müllgruben und Deponien entsorgten Materialmenge zu reduzieren. In Übereinstimmung mit dieser Bestimmung dürfen elektrische und elektronische Geräte (WEEE) nicht mit dem unsortierten Müll von Privathaushalten oder Büros entsorgt werden. Sie müssen vielmehr einer gesonderten Abfallentsorgung zugeführt werden. Die Entsorgung dieser Geräte an Stellen, die dafür weder ausgerüstet noch zugelassen sind, hat verheerende Folgen auf Umwelt und Gesundheit. Zuwiderhandlungen werden mit den gesetzlichen Strafen und Bußgeldern belegt.

Die Panini-Produkte sind daher in Entsprechung der europäischen WEEE-Richtlinie über Elektro- und Elektronikaltgeräte (WEEE) mit dem Symbol einer durchgestrichenen Mülltonne gekennzeichnet, das darauf hinweist, dass alle nach dem 13. August 2005 auf dem Markt eingeführten Produkte dieser Art gemäß WEEE-Richtlinie 2002/96/EC (und folgender Zusätze) nicht mit dem normalen Hausmüll entsorgt werden dürfen.



So entsorgen Sie die Altgeräte umweltgerecht:

- Wenden Sie sich an die lokalen Behörden oder an Ihren Fachhändler, die Ihnen die notwendigen Informationen zur korrekten Entsorgung liefern werden, wie zum Beispiel: Ort und Öffnungszeiten der Abfallsammelstellen usw.
- Wenn Sie ein neues Gerät von uns kaufen, können Sie ein ähnliches Altgerät unserem Fachhändler zur Entsorgung übergeben.

FÜR ANDERE (NICHT DER EU ANGEHÖRIGE) LÄNDER

Die Behandlung, Sammlung, Wiederverwertung und Entsorgung von Elektro- und Elektronikaltgeräten erfolgt in Entsprechung der in dem betreffenden Land gültigen Bestimmungen.

10.1 Audience

Das vorliegende Handbuch ist vornehmlich für das Personal bestimmt, das Schecks und andere Dokumente bearbeitet.

10.2 Sicherheitsmaßnahmen

Vergewissern Sie sich, bevor Sie mit dem Gerät Vision X arbeiten oder das Gerät warten, dass Sie die Sicherheitsanweisungen gelesen und verstanden haben.

- Tragen Sie sichere Kleidung. Vermeiden Sie das Tragen lockerer Kleider, langer Haare und von Schmuck, die sich in den sich bewegenden Teilen verfangen können.
- Achten Sie darauf, dass niemand auf dem Stromkabel steht. Stellen Sie Vision X nicht in Bereichen auf, in denen Leute auf das Kabel treten können.
- Ziehen Sie vor dem Reinigen des Gerätes Vision X immer den Netzstecker.
- Versuchen Sie nicht, Vision X selbst zu warten oder zu reparieren, soweit dies im Handbuch nicht ausdrücklich erwähnt wird.
- Der Versuch, den externen Netzanschluss selbst zu warten oder zu reparieren, setzt Sie gefährlichen Spannungen oder anderen Gefahren aus.
- Wenden Sie sich immer an erfahrene Wartungsfachkräfte.

Hinweis:

- Vision X entspricht den Normen IEC/EN 60950-1 und UL 60950-1 nur, wenn es mit dem Netzteil DSA-0421S-28 1 42 verwendet wird, das mit der Maschine geliefert wird.
- Die Wandsteckdose muss in der Nähe des Gerätes installiert werden und immer leicht zugänglich sein.
- BETRIEBSBEDINGUNGEN: Temperatur: 15 ÷ 35°C. Relative Luftfeuchtigkeit: 20 ÷ 80% ohne Kondensation.

10.3 Bei Maschinenstörungen

Ziehen Sie den Netzstecker des Gerätes Vision X und rufen Sie eine Fachkraft, wenn sich folgende Bedingungen einstellen:

- Wenn das Netzkabel beschädigt oder abgenutzt ist.
- Wenn Flüssigkeit in das Produkt eingedrungen ist.
- Wenn das Gerät Regen oder Wasser ausgesetzt worden ist.
- Wenn das Gerät bei Befolgung der Bedienungsanweisungen nicht korrekt funktioniert.
- Wenn das Gerät beschädigt oder hingefallen ist.
- Wenn die Geräteleistungen deutlich nachlassen und damit anzeigen, dass das Gerät gewartet werden muss.

Nehmen Sie nur solche Einstellungen vor und ersetzen Sie nur Bauteile, die in diesem Handbuch erwähnt werden.

Wenn Sie versuchen, Einstellungen vorzunehmen, die nicht in dem Handbuch erwähnt werden, laufen Sie Gefahr, das Gerät zu beschädigen; außerdem verfällt die Garantie.

Ungenehmigte Einstellungen oder Reparaturen können später außergewöhnliche Arbeiten durch eine Fachkraft erfordern, um das Gerät wieder in die normalen Betriebsbedingungen zu versetzen.

10. Mise au rebut des équipements électriques et électroniques (WEEE)

POUR LES PAYS DE L'UNION EUROPÉENNE (UE)

L'Union européenne a établi que les équipements électriques et électroniques actuellement sur le marché contiennent des composants et des matériaux pouvant être réutilisés ou recyclés afin de réduire la masse de déchets jetés dans des centres d'enfouissement et autres décharges. Dans cette optique, l'UE appelle à ne pas collecter ou jeter les déchets d'équipements électriques et électroniques (WEEE) avec des déchets tout venant issus des ménages ou des entreprises. Ils doivent faire l'objet d'une collecte sélective. La mise au rebut de (WEEE) dans des décharges non équipées et non homologuées peut avoir des conséquences nocives pour la santé et l'environnement. Les contrevenants s'exposent aux sanctions et autres mesures établies par la loi.

Dans cette optique, les produits Panini portent le pictogramme de la « poubelle barrée » prévu par la Directive (WEEE) de l'Union européenne. Ce pictogramme indique l'obligation de procéder à la collecte sélective des équipements électriques et électroniques mis sur le marché après le 13 août 2005, conformément à la directive européenne (WEEE) 2002/96/CE (et à ses amendements suivants), ainsi qu'aux lois en vigueur dans chaque pays.



Pour la mise au rebut de vos (WEEE):

- demandez aux autorités locales compétentes ou à un distributeur local de vous donner les informations pratiques et les indications dont vous avez besoin pour une gestion appropriée de vos déchets comme, par exemple, l'adresse et les horaires des centres de collecte des déchets, etc.
- quand vous achetez un nouvel appareil électrique ou électronique, remettez votre ancien appareil au revendeur pour qu'il se charge de son élimination.

POUR LES AUTRES PAYS (HORS UE)

Le traitement, la collecte, le recyclage et l'élimination des équipements électriques et électroniques doivent être effectués conformément à la législation en vigueur dans le pays concerné.

10.1 Destinataires

Ce manuel s'adresse principalement au personnel chargé du traitement de chèques ou d'autres documents.

10.2 Consignes de sécurité

Avant l'utilisation ou la maintenance de votre Vision X conformément aux indications de ce manuel, il est important d'avoir entièrement lu et bien compris ces consignes de sécurité.

- Portez des vêtements appropriés. Ne portez pas de vêtements amples ou de bijoux et attachez les cheveux longs pour éviter qu'ils ne soient happés par les pièces en mouvement.
- Ne posez aucun objet sur le cordon d'alimentation. Installez le Vision X en veillant à ce que personne ne risque de marcher sur le cordon d'alimentation.
- Débranchez toujours le Vision X avant de le nettoyer.
- Ne tentez pas d'intervenir sur le Vision X pour sa maintenance ou sa réparation, sauf pour les interventions explicitement décrites dans ce manuel.
- Toute tentative d'intervenir sur l'alimentation externe du Vision X expose l'opérateur à des hautes tensions ou d'autres dangers.
- Pour toutes les opérations d'entretien et les réparations, faites appel à du personnel de maintenance qualifié.

Remarque:

- Le Vision X n'est conforme aux normes CEI/EN 60950-1 et UL 60950-1 qu'en cas d'utilisation de l'alimentation modèle DSA-0421S-28 1 42 fournie avec la machine.
- La prise de courant doit être installée près de l'équipement et doit être facilement accessible.
- CONDITIONS DE FONCTIONNEMENT: Température: 15 ÷ 35°C. Humidité: 20 ÷ 80 % H.R. sans condensation.

10.3 Si l'appareil est endommagé

Débranchez le Vision X de la prise murale et faites appel à du personnel qualifié :

- si le cordon d'alimentation est endommagé ou fissuré ;
- si du liquide a pénétré dans l'appareil ;
- si l'appareil a été exposé à la pluie ou à de l'eau ;
- si l'appareil ne fonctionne pas normalement bien que les instructions d'utilisation aient été respectées ;
- si l'appareil est tombé ou a subi des dommages ;
- si l'appareil a besoin d'une vérification suite à une altération quelconque de son fonctionnement.

Procédez uniquement aux réglages et aux remplacements décrits dans ce manuel.

Si vous tentez d'effectuer un réglage non indiqué dans ce manuel, vous risquez de causer des dommages à l'appareil. Ces dommages ne sont pas couverts par la garantie.

Les réglages ou réparations effectués sans autorisation peuvent exiger l'intervention d'un technicien qualifié pour rétablir les conditions de fonctionnement de l'appareil.

10. Smaltimento corretto delle apparecchiature elettriche ed elettroniche (WEEE)

PER I PAESI MEMBRI DELL'UNIONE EUROPEA (EU)

La Commissione dell'Unione Europea ha stabilito che le apparecchiature elettriche ed elettroniche attualmente presenti sul mercato contengono parti e componenti che possono essere adeguatamente riutilizzati o riciclati per ridurre le quantità di materiali destinati in ultimo alle discariche e ad altri siti di smaltimento. Per rispettare questa decisione, le apparecchiature elettriche ed elettroniche (WEEE) non devono essere raccolte o smaltite nei normali cassonetti di raccolta sia dai privati cittadini che dalle aziende. Devono invece essere oggetto di raccolta differenziata. La discarica di questi dispositivi presso luoghi non adeguatamente attrezzati e non autorizzati può avere effetti nocivi sulla salute e sull'ambiente. I trasgressori saranno passibili delle sanzioni e dei provvedimenti previsti dalla legge.

A tal fine, i prodotti Panini sono debitamente contrassegnati dal marchio stabilito dalla direttiva WEEE dell'Unione Europea, costituito dal simbolo da un bidone della spazzatura barrato da una croce per indicare che le apparecchiature elettriche ed elettroniche immesse sul mercato dopo il 13 agosto 2005 devono essere smaltite in modo differenziato, ai sensi della Direttiva WEEE 2002/96/CE (e successivi emendamenti) e della legislazione nazionale.

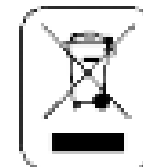

Per smaltire i nostri dispositivi correttamente:

- Contattare le autorità o il distributore locali, che forniranno le informazioni pratiche e le istruzioni necessarie per smaltire correttamente il prodotto, per esempio: luogo e orari dei centri di raccolta rifiuti, ecc.
- Al momento dell'acquisto di un nostro nuovo dispositivo, è possibile consegnare un dispositivo simile a quello acquistato al nostro distributore, che si occuperà dello smaltimento.

PER ALTRI PAESI (EXTRA UE)

Il trattamento, la raccolta, il riciclaggio e lo smaltimento delle apparecchiature elettriche ed elettroniche dovrà avvenire in conformità alle leggi in vigore nel paese di residenza.

10.1 A chi è rivolto il presente manuale

Il presente manuale è rivolto principalmente al personale che elabora gli assegni o altri documenti.

10.2 Precauzioni di sicurezza

Prima di mettere in funzione o effettuare interventi di manutenzione su Vision X nel rispetto delle istruzioni del presente manuale, assicurarsi di aver letto e compreso le presenti importanti istruzioni di sicurezza.

- Indossare indumenti sicuri. Non indossare indumenti larghi, non portare capelli sciolti o gioielli che potrebbero rimanere impigliati nelle parti in movimento dell'apparecchio.
- Non appoggiare oggetti sul cavo di alimentazione. Non posizionare Vision X in punti in cui sia possibile calpestare il cavo di alimentazione.
- Staccare sempre Vision X dalla presa di alimentazione prima di pulirlo.
- Non tentare di effettuare interventi di manutenzione o riparazione su Vision X, eccetto secondo le istruzioni impartite in altri punti del presente manuale.
- Eventuali tentativi di manutenzione o riparazione dell'alimentatore esterno di Vision X possono esporre a pericolosi picchi di tensione o ad altri rischi.
- Per tutti gli aspetti della manutenzione, fare riferimento a personale qualificato.

Nota:

- Vision X sarà conforme alle norme CEI/EN 60950-1 e UL 60950-1 solo utilizzando l'alimentatore modello DSA-0421S-28 1 42 fornito in dotazione con l'apparecchio.
- La presa deve essere installata nelle vicinanze dell'apparecchio e in una posizione facilmente accessibile.
- CONDIZIONI DI ESERCIZIO: Temperatura: 15 ÷ 35°C. Umidità: 20 ÷ 80% Umidità relativa non condensante.

10.3 Se l'apparecchio è danneggiato

Scollegare la spina di Vision X dalla presa a muro e, nei seguenti casi, rivolgersi a personale qualificato per un intervento di manutenzione:

- Se il cavo di alimentazione è danneggiato o usurato.
- Se è penetrato del liquido nell'apparecchio.
- Se l'apparecchio è stato esposto a pioggia o acqua.
- Se l'apparecchio non funziona normalmente pur rispettando le istruzioni di sicurezza.
- Se l'apparecchio è caduto o ha subito danni.
- Se l'apparecchio mostra chiari segni di calo di prestazioni, indicando così la necessità di un intervento di manutenzione.

Regolare unicamente i comandi e sostituire solo le parti coperte da istruzioni nel presente manuale.

Tentando di effettuare regolazioni non coperte dal presente manuale, l'apparecchio si potrebbe danneggiare, invalidando pertanto la garanzia.

Regolazioni o riparazioni non autorizzate possono determinare la necessità di un lungo intervento da parte di un tecnico qualificato per riportare l'apparecchio alle corrette condizioni di funzionamento.

10. *Cómo deshacerse correctamente de los equipos eléctricos y electrónicos (WEEE)*

PARA LOS PAÍSES DE LA UNIÓN EUROPEA (UE)

La Comisión Europea ha determinado que los equipos eléctricos y electrónicos comercializados actualmente contienen piezas y componentes que se pueden volver a utilizar o reciclar para reducir las cantidades de materiales que invaden los vertederos y otras zonas destinadas a los desechos. Con el fin de respetar esta decisión, los residuos de aparatos eléctricos y electrónicos (WEEE) no deberían ser recogidos ni eliminados junto con los residuos sin clasificar de los hogares o empresas. Se deben recoger por separado. Arrojar estos dispositivos en lugares no-equipados o no-autorizados puede tener consecuencias peligrosas para la salud y el medioambiente. Los infractores sufrirán las penas y las medidas establecidas por ley.

Por todo ello, los productos Panini están debidamente marcados con el símbolo de la papelera tachada, según obliga la normativa (WEEE) de la Unión Europea, para indicar que es necesario realizar una recogida selectiva de los aparatos eléctricos y electrónicos comercializados después del 13 de agosto de 2005, con arreglo a la normativa (WEEE) 2002/96/EC (y sus posteriores enmiendas) y según las leyes nacionales de cada país miembro.



Para deshacerse de los aparatos correctamente:

- Póngase en contacto con las Autoridades Locales o con su distribuidor local, quien le proporcionará la información práctica que necesite y las instrucciones para desechar correctamente el aparato, por ejemplo: Ubicación y horarios de los centros de recogida, etc.
- Cuando compre un aparato nuevo de Panini, entregue a nuestro distribuidor un aparato similar usado para que lo deseche.

PARA OTROS PAÍSES (FUERA DE LA UE)

El tratamiento, la recogida, el reciclaje y la eliminación de aparatos eléctricos y electrónicos se realizarán con arreglo a las leyes en vigor en el país en cuestión.



10.1 Público objetivo

Este manual ha sido redactado principalmente para el personal que realiza las comprobaciones o procesa otros documentos.

10.2 Instrucciones de Seguridad

Antes de empezar a utilizar el Vision X tal y como se indica en este manual, asegúrese de leer y comprender estas importantes instrucciones de seguridad.

- Debe vestirse con prendas seguras. No lleve ropa floja, pelo largo o joyas que puedan engancharse en las piezas en movimiento.
- No permita que nada repose sobre el cable eléctrico. No coloque el Vision X donde alguien pueda pisar el cable.
- Desconecte siempre el Vision X antes de limpiarlo.
- No intente realizar el mantenimiento o las reparaciones del Vision X, de otra forma que no se la indicada en este manual.
- Si intenta realizar el mantenimiento o las reparaciones del suministro de potencia externo del Vision X puede exponerse a picos de tensión peligrosos u otros riesgos.
- Encargue siempre el mantenimiento al personal de servicio cualificado.

Nota:

- Vision X respetará las normas IEC/EN 60950-1 y UL 60950-1 utilizando sólo el modelo de Suministro de Energía DSA-0421S-28 1 42 suministrado con el aparato.
- La salida del enchufe deberá estar instalada cerca del equipo y deberá ser fácil acceder a ella.
- CONDICIONES DE FUNCIONAMIENTO: Temperatura: 15 ÷ 35°C. Humedad: 20 ÷ 80% H.R. Sin condensación.

10.3 Si el Aparato Está Estropeado

Desenchufe el Vision X de la toma de corriente de la pared y encargue el mantenimiento al personal cualificado si se dan las siguientes condiciones:

- Si el cable eléctrico está dañado o desgastado.
- Si se ha derramado líquido en el producto.
- Si el aparato ha quedado expuesto a la lluvia o el agua.
- Si el aparato no funciona con normalidad cuando se siguen las instrucciones de funcionamiento.
- Si el aparato ha quedado expuesto a la lluvia o el agua.
- Si el aparato muestra un claro cambio en el funcionamiento que indique que hay que repararlo.

Ajuste sólo los controles y repare sólo los elementos cubiertos por las instrucciones de este manual.

Si intenta realizar ajustes que no estén cubiertos en este manual, puede dañar el aparato e invalidar la garantía.

Los ajustes o reparaciones no-autorizados pueden requerir posteriormente un trabajo más importante a cargo de un técnico cualificado, con vistas a restituir al aparato sus condiciones de funcionamiento adecuadas.

10. Eliminação adequada de equipamento eléctrico e electrónico (WEEE)

PARA PAÍSES PERTENCENTES À UNIÃO EUROPEIA (UE)

A Comissão Europeia da União Europeia determinou que o equipamento eléctrico e electrónico no mercado actual contém partes e componentes que podem ser devidamente recuperados e reciclados para reduzir as quantidades de materiais eliminados em lixeiras e aterros. Para cumprir esta determinação, os resíduos de equipamento eléctrico e electrónico (WEEE) não devem ser recolhidos ou eliminados juntamente com lixo indiferenciado proveniente de casas particulares ou empresas. Em vez disso, devem ser recolhidos separadamente. A descarga destes dispositivos em locais não equipados e não autorizados pode ter efeitos prejudiciais para a saúde e o meio ambiente. Os transgressores serão sujeitos a multas e medidas estabelecidas pela legislação. Neste sentido, os produtos Panini estão devidamente marcados com o símbolo do caixote do lixo barrado com uma cruz (Directiva (WEEE) da União Europeia), para indicar a necessidade de uma recolha separada de equipamento eléctrico e electrónico comercializado após 13 de Agosto de 2005, de acordo com a directiva (WEEE) 2002/96/CEE (e posteriores alterações) e a legislação nacional.

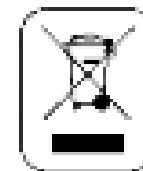

Para eliminar os aparelhos correctamente:

- Contacte as autoridades competentes ou o distribuidor local, que lhe fornecerá as informações práticas de que necessita e as instruções para o tratamento adequado do lixo, por exemplo: localização e horário dos centros de recolha de resíduos, etc.
- Quando adquirir um novo aparelho, entregue ao seu distribuidor um aparelho usado semelhante ao que acabou de adquirir, para garantir uma eliminação adequada.

PARA OUTROS PAÍSES (NÃO PERTENCENTES À UE)

O tratamento, recolha, reciclagem e eliminação de aparelhos eléctricos e electrónicos será efectuado de acordo com a legislação em vigor no país em questão.

10.1 Público alvo

Este manual destina-se principalmente ao pessoal responsável pelas verificações ou outros documentos.

10.2 Precauções de segurança

Antes de começar a utilizar ou a efectuar a manutenção do seu Vision X de acordo com as instruções neste manual, certifique-se de que leu e compreendeu estas importantes precauções de segurança.

- Use vestuário de protecção. Não use roupa folgada, cabelo comprido ou jóias que possam ficar presas nas partes em movimento.
- Não apoie nada no cabo de alimentação. Não coloque o Vision X em locais onde as pessoas possam pisar o cabo.
- Desligue sempre o Vision X antes das operações de limpeza.
- Não tente efectuar operações de manutenção ou reparação no Vision X, salvo indicações em contrário neste manual.
- A tentativa de efectuar operações de manutenção ou reparação na alimentação externa do Vision X pode expô-lo a picos de tensão perigosos ou outros riscos.
- Confie estas operações a pessoal de assistência qualificado.

Nota:

- O Vision X estará em conformidade com as normas IEC/EN 60950-1 e UL 60950-1 utilizando apenas o modelo de alimentação de energia DSA-0421S-28 1 42 fornecido com a máquina.
- A tomada será instalada próximo do equipamento e deverá estar facilmente acessível.
- CONDIÇÕES DE FUNCIONAMENTO: Temperatura: 15 ÷ 35°C. Humidade: 20 ÷ 80% H.R. não condensada.



10.3 Se a máquina estiver danificada

Desligue o Vision X da tomada e confie as operações de manutenção a pessoal qualificado nas seguintes condições:

- Se o cabo de alimentação estiver gasto ou danificado.
- Se se derramar líquido no produto.
- Se o equipamento tiver sido exposto à chuva ou água.
- Se o equipamento não funcionar normalmente quando se seguem as instruções de funcionamento.
- Se o equipamento tiver caído ou estiver danificado.
- Se o equipamento apresentar uma alteração visível em termos de desempenho, indicando uma necessidade de manutenção.

Ajuste apenas estes comandos e substitua apenas as peças abrangidas neste manual de instruções.

Se tentar realizar ajustes não abrangidos neste manual, poderá danificar o equipamento e anular a garantia.

Ajustes ou reparações não autorizados podem resultar na necessidade de operações alargadas por parte de um técnico qualificado para fazer regressar o equipamento à sua condição de funcionamento adequada.

10. Correct afdanken volgens de elektrische en elektronische apparaten WEEE-richtlijn

VOOR LANDEN IN DE EUROPESE UNIE (EU)

De Europese Commissie van de Europese Unie heeft bepaald dat elektrische en elektronische apparaten die tegenwoordig op de markt zijn onderdelen en componenten bevatten die op correcte wijze hergebruikt of gerecycled kunnen worden teneinde de hoeveelheid materiaal die uiteindelijk op stortterreinen en andere afvalplaatsen terecht komt te verminderen. Om aan deze bepaling te voldoen, mag afgedankte elektrische en elektronische apparatuur (WEEE) niet ingezameld of weggegooid worden samen met ongesorteerd afval van particuliere huishoudens of bedrijven. Het dient daarentegen gescheiden te worden ingezameld. Het weggoien van deze apparaten op plaatsen die daarvoor niet ingericht en bevoegd zijn kan gevaarlijke gevolgen hebben voor de gezondheid en het milieu. Overtreders zullen onderworpen worden aan de in de wet vastgestelde boetes en maatregelen.

Daarom zijn de producten van Panini overeenkomstig voorzien van het door de Europese WEEE-richtlijn voorgeschreven symbool van de doorgekruiste verrijdbare afvalbak om de vereiste aan te geven van gescheiden inzameling van elektrische en elektronische apparatuur die na 13 augustus 2005 op de markt is gebracht, in overeenstemming met de WEEE-richtlijn 2002/96/EG (en hierna volgende amendementen) en uw nationale wetten.



Om uw apparatuur op de juiste wijze af te danken:

- kunt u contact opnemen met de plaatselijke autoriteiten of plaatselijke distributeur, die u de noodzakelijke praktische informatie en de aanwijzingen voor het op de juiste hanteren van het afval zal geven, bijvoorbeeld: plaats en openingstijden van de afvalinzamelcentra, enz.
- Indien u een nieuw apparaat van ons aanschaft, lever dan een vergelijkbaar apparaat in bij onze distributeur voor verwerking tot afval.

VOOR ANDERE LANDEN (NIET BINNEN DE EU)

De behandeling, inzameling, recycling en afvalverwerking van elektrische en elektronische apparatuur dient te geschieden in overeenstemming met de geldende wetten in het betreffende land.

10.1 Doelgroep

Deze handleiding is in de eerste plaats geschreven voor personeel die controles uitvoert of andere documenten samenstelt.

10.2 Veiligheidsmaatregelen

Verzeker u er alstublieft van dat u, voordat u uw Vision X in gebruik neemt of enig onderhoud verricht zoals beschreven in deze handleiding, deze belangrijke veiligheidsinstructies gelezen en begrepen hebt.

- Draag veilige kleding. Draag geen loshangende kleding, lang haar of juwelen die verstrikt kunnen raken in bewegende delen.
- Laat niets op het voedingsnoer staan. Zet de Vision X niet op plaatsen waar mensen over het snoer kunnen lopen.
- Trek de stekker van de Vision X altijd uit het stopcontact voordat u hem schoonmaakt.
- Probeer geen onderhoud of reparaties te verrichten aan de Vision X, behalve als deze handelingen elders in deze handleiding beschreven zijn.
- Als u probeert onderhoud of reparaties te verrichten aan de externe elektrische voeding van de Vision X loopt u het risico van blootstelling aan een hoog voltage of andere risico's.
- Laat alle onderhoudswerkzaamheden over aan gekwalificeerd onderhoudspersoneel.

Opmerking:

- De Vision X voldoet alleen aan de norm IEC/EN 60950-1 en UL 60950-1 wanneer de Voeding, model DSA-0421S-28 1 42, die bij de machine geleverd is, gebruikt wordt.
- De uitgang van het stopcontact dient vlakbij de apparatuur geïnstalleerd te worden en moet makkelijk toegankelijk zijn.
- BEDIENINGSVOORWAARDEN: Temperatuur: 15 ÷ 35°C. Vochtigheidsgraad: 20 ÷ 80% R.H. Niet-Condenerend.

10.3 Als de machine beschadigd is

Trek de stekker van de Vision X uit het stopcontact en wend u voor onderhoud tot gekwalificeerd personeel, in de volgende omstandigheden:

- Als de voedingskabel beschadigd of gerafeld is.
- Als er vloeistof in het product gemorst is.
- Als de apparatuur blootgesteld geweest is aan regen of water.
- Als de apparatuur niet normaal werkt terwijl de bedieningsinstructies zijn opgevolgd.
- Als de apparatuur gevallen of beschadigd is.
- Als de apparatuur een duidelijke verandering in de prestatie vertoont, hetgeen aangeeft dat onderhoud nodig is.

Stel alleen die bedieningselementen af en vervang uitsluitend die onderdelen die beschreven zijn in de instructies in deze handleiding.

Als u tracht aanpassingen te maken die niet zijn beschreven in deze handleiding, kunt u de apparatuur beschadigen en de garantie ongeldig maken.

Onbevoegde aanpassingen of reparaties kunnen leiden tot de noodzaak van uitgebreide werkzaamheden door een gekwalificeerd technicus, om de apparatuur weer terug te brengen in de toestand van goede werking.

10. Korrekt kassering av elektrisk og elektronisk utstyr (WEEE)

FOR LAND I DEN EUROPEISKE UNION (EU)

Europakommisjonen i EU har slått fast at elektrisk og elektronisk utstyr på dagens marked inneholder deler og komponenter som på korrekt vis kan brukes på nytt eller bli resirkulert, slik at mengdene av materialer som tilslutt blir kastet på fyllplasser og andre søppelområder, reduseres. For å forholde seg til denne beslutningen må man ikke samle opp eller kaste elektrisk og elektronisk utstyr sammen med usortert søppel fra privathusholdninger eller fra forretningsvirksomheter. Det må derimot samles inn særskilt. Det kan ha skadelig innvirkning på helse og miljø hvis slike innretninger kastes på steder som ikke har autorisasjon eller utstyr. Gjerningspersoner vil kunne bli gjenstand for de straffereaksjoner og -tiltak som er fastsatt i lovverket. I denne sammenheng er Panini-produktene korrekt merket med symbolet bestående av en søppelbøtte med et kryss over, som angitt i EUs WEEE-direktiv. Dette angir kravet om særskilt innsamling av elektrisk og elektronisk utstyr som kom på markedet etter 13. august 2005 i henhold til WEEE-direktiv 2002/96/EC (og senere endringer) og din nasjonale lovgivning.



Slik kasserer du innretningene på korrekt vis:

- Kontakt lokale myndigheter eller lokal distributør, som vil gi deg den praktiske informasjonen du behøver og veiledninger for å håndtere søppel korrekt, for eksempel: Lokasjon og åpningstider til søppelopsamlingssentrene osv.
- Når du kjøper en ny innretning fra oss, kan du gi til distributøren vår en innretning som er lik den du kjøper, for kassering.

FOR ANDRE LAND (IKKE I EU)

Behandlingen, innsamlingen, resirkuleringen og kasseringen av elektriske og elektroniske innretninger vil bli utført i samsvar med lovverket som gjelder i det aktuelle landet.

10.1 Målgruppe

Denne håndboken er hovedsakelig skrevet for personer som behandler kontroller og andre dokumenter.

10.2 Sikkerhetsforanstaltninger

Før du begynner å bruk eller foreta service på Vision X som angitt i denne håndboken, må du lese og forstå disse viktige sikkerhetsveiledningene.

- Kle deg sikkert. Ikke bruk løstsittende klær, ikke ha langt hår eller smykker som kan henge seg opp i bevegelige deler.
- Ikke la noe ligge oppå strømledningen. Ikke plasser Vision X der du risikerer at noen trækker på ledningen.
- Koble alltid Vision X fra før rengjøring.
- Ikke prøv å utføre service eller reparasjoner på Vision X bortsett fra det som det er gitt veiledning om andre steder i denne håndboken.
- Du kan bli utsatt for farlig spenning eller andre farer hvis du prøver å utføre service eller reparasjoner på den eksterne strømforsyningen til Vision X.
- Henvis all service til kvalifisert servicepersonell.

Merk:

- Vision X er i samsvar med standarden IEC/EN 60950-1 og 60950-1 kun bruk av strømforsyningsmodell DSA-0421S-28 1 42 som leveres med maskinen.
- Kontaktuttaket må installeres nær utstyret og være lett tilgjengelig.
- BRUKSFORHOLD: Temperatur: 15 ÷ 35° C. Fuktighet: 20 ÷ 80 % R.H. ikke-kondenserende.

10.3 Hvis maskinen er skadet

Trekk ut ledningen til Vision X fra uttaket i veggen, og henvis servicen til kvalifisert personell under følgende forhold:

- Hvis strømledningen er skadet eller slitt.
- Hvis det er sølt væske inn i produktet.
- Hvis utstyret har vært utsatt for regn eller vann.
- Hvis utstyret ikke virker normalt når bruksveiledningene følges.
- Hvis utstyret har falt i bakken eller er blitt skadet.
- Hvis utstyret viser en tydelig endring i ytelsen, som angir behov for service.

Juster kun de kontrollene, og bytt kun ut de elementene som omfattes av veiledningene i denne håndboken.

Hvis du prøver å foreta justeringer som ikke omfattes av denne håndboken, kan du skade utstyret og ugyldiggjøre garantien.

Uautoriserte justeringer eller reparasjoner kan føre til at det blir nødvendig med omfattende arbeider utført av kvalifisert tekniker for at utstyret skal bli satt tilbake i skikkelig stand.

10. Korrekt kassering av elektroniska komponenter enligt (WEEE)

FÖR LÄNDER INOM DEN EUROPEISKA UNIONEN (EU)

Europakommissionen i den Europeiska Unionen har fastställt att elektronisk utrustning som finns på marknaden idag innehåller delar och komponenter som kan återanvändas eller återvinnas för att minska den mängd material som slutligen hamnar på tippen och andra sopförvaringsplatser. För att tillgodose denna bestämmelse skall avfall från elektriska och elektroniska produkter (WEEE) inte samlas upp tillsammans med osorterat avfall från privata hushåll eller företag. Det skall istället samlas in separat. Att dumpa dessa apparater på icke härför utrustade eller icke-auktoriserade platser kan ha en farlig inverkan på vår hälsa och miljö. Lagöverträdare blir föremål för de åtal och straff som lagen föreskriver.

Därför är Panini-produkter märkta med det härför avsedda EU-märket (WEEE): en symbol med en överkryssad soptunna som visar att den skall gå till separat uppsamling enligt den lag som säger att elektriska och elektroniska produkter som når marknaden efter den 13 augusti 2005 skall återvinnas enligt WEEE-direktivet 2002/96/EG (och senare tillägg) och enligt lokal lagstiftning.



För att skrota våra produkter på ett korrekt vis:

- Kontakta dina lokala myndigheter eller din lokala återförsäljare: de kan ge dig de praktiska upplysningar som du behöver och alla instruktioner om hur du korrekt skall behandla dessa sopor, till exempel: plats och öppettider för sopstationer, osv
- Då du handlar en ny apparat av oss, kan du lämna den gamla apparaten hos vår återförsäljare som ser till att skrota den på korrekt vis.

FÖR ANDRA LÄNDER (UTANFÖR DEN EUROPEISKA UNIONEN (EU))

Behandling, insamling, återvinning och skrotning av elektrisk och elektronisk utrustning skall utföras i enlighet med de lokala lagarna i landet i fråga.

10.1 Målgrupp

Denna manual är först och främst skriven för den personal som utför kontroll och annan dokumentation.

10.2 Säkerhetsföreskrifter

Innan du börjar använda eller serva din VisionX enligt instruktionerna i denna manual, skall du läsa och förstå dessa viktiga säkerhetsinstruktioner.

- Klä dig säkert. Använd inte lössittande kläder eller smycken, och ha inte långt hår - dessa kan alla fastna i rörliga delar.
- Se till att ingenting står på strömkabeln. Placera inte VisionX på en plats där folk måste kliva på eller över strömkabeln.
- Koppla alltid loss VisionX från strömförande nät innan du rengör den.
- Utför inget underhåll eller reparation på VisionX, förutom enligt de instruktioner du finner i denna manual.
- Att försöka serva eller reparera det yttre strömförsörjningspaketet på VisionX kan utsätta dig för farligt höga vottal och andra risker.
- Se till att allt underhållsarbete utförs av kvalificerad underhållspersonal.

OBS:

- Vision X är endast i överensstämmelse med standard IEC/EN 60950-1 och UL 60950-1 om Strömförsörjningsenhet av modell DSA-0421S-28 1 42 används, den medföljer maskinen.
- Väggttaget skall vara placerat i närheten av utrustningen och skall vara lättåtkomligt.
- DRIFTSFÖRHÅLLANDEN: Temperatur: 15 ÷ 35 °C. Luftfuktighet: 20 ÷ 80 % relativ luftfuktighet, icke-kondenserande.

10.3 Om maskinen är skadad

Koppla bort Vision X från strömförande nät och se till att underhållet utförs av kvalificerad personal vid dessa tillfällen:

- Om den strömförande kabeln är skadad eller sliten.
- Om vätska spillts i maskinen.
- Om utrustningen har utsatts för regn eller vatten.
- Om utrustningen inte fungerar normalt trots att driftsinstruktionerna följs.
- Om utrustningen har tappats eller skadats.
- Om utrustningen uppvisar nedsatt prestanda, något som tyder på behov för underhåll.

Justera endast de reglage och byt endast ut de delar som finns omnämnda i denna manual.

Om du försöker att justera sådant som inte behandlas i denna manual, kan du eventuellt skada utrustningen och då ogiltigförklaras garantin.

Icke-auktoriserade ingrepp eller reparationer kan resultera i betydande arbetsinsats av en kvalificerad tekniker för att återställa utrustningen till dess korrekta driftskondition.

10. Sähkö- ja elektroniikkalaitteiden oikea hävittäminen (WEEE)

EUROOPAN UNIONIN MAAT (EU)

Euroopan Unionin komissio on päättänyt, että nykyään markkinoilla olevat sähköiset ja elektroniset laitteet sisältävät osia ja komponentteja, joita voidaan uudelleenkäyttää tai kierrättää sellaisten jätteiden vähentämiseksi, jotka käytetään täyttömaana tai viedään kaatopaikalle. Tämän päätöksen mukaisesti sähkö- ja elektroniikkalaiteromua (WEEE) ei saa kerätä tai hävittää yhdessä lajittelemattomien kotitalous- tai yhdyskuntajätteiden kanssa. Se on kerättävä erikseen. Näiden laitteiden jättäminen varustelemattomiin tai valtuuttamattomiin paikkoihin saattaa aiheuttaa vaaraa terveydelle ja ympäristölle. Rikkomuksentekijöitä rangaistaan lain mukaisesti.

Tätä varten Panini-tuotteet on asianmukaisesti merkitty Euroopan Unionin WEEE-direktiivin mukaisella merkillä, jossa on risti jäteastian päällä, joka osoittaa, että 13. elokuuta 2005 jälkeen markkinoille tulleet sähkö- ja elektroniikkalaitteet täytyy WEEE-direktiivin 2002/96/EY (ja myöhempien muutosten) mukaisesti kerätä erikseen.



Laitteiden asianmukainen hävittäminen:

- Ota yhteys paikallisiin viranomaisiin tai jälleenmyyjään, joilta saat tarvitsemasi käytännön tiedot ja ohjeet romun käsittelystä varten, esimerkiksi: keräyskeskusten sijainti ja aukioloajat jne.
- Kun hankit uuden laitteen, palauta samanlainen käytetty laite jälleenmyyjälle hävittämistä varten.

MUUT MAAT (EI EU)

Sähkö- ja elektroniikkaromun käsittely, kerääminen, kierrätys ja hävittäminen on tehtävä maassa voimassa olevien lakien mukaisesti.

10.1 Kenelle opas on tarkoitettu

Tämä opas on laadittu ennen kaikkea henkilökunnalle, joka käsittelee shekkejä tai muita asiakirjoja.

10.2 Turvallisuusvarotoimet

Varmista, että olet lukenut ja ymmärtänyt nämä tärkeät turvaohjeet ennen kuin alat käyttää tai huoltaa Vision X -laitetta.

- Pukeudu turvallisesti. Älä käytä löysiä vaatteita, älä pidä pitkää tukkaa auki, älä käytä koruja, jotka saattavat tarttua liikkuviin osiin.
- Virtajohdon päällä ei saa olla mitään. Älä sijoita Vision X -laitetta paikkaan, jossa joku voi kävellä johdon päällä.
- Irrota pistoke aina pistorasiasta ennen Vision X -laitteen puhdistamista.
- Älä yritä huoltaa tai korjata Vision X -laitetta muuten kuin tässä oppaassa kuvatulla tavalla.
- Vision X:n virtajohdon huolto- tai korjausyritykset saattavat aiheuttaa sähköisku- tai muun vaaran.
- Anna kaikki huoltotoimet pätevän henkilökunnan tehtäväksi.

Huomaa:

- Vision X vastaa standardeja IEC/EN 60950-1 ja UL 60950-1 vain kun käytetään koneen mukana toimitettua virtajohtoa, malli DSA-0421S-28 1 42.
- Pistorasian täytyy olla laitteen lähellä ja sen on oltava helposti saavutettavissa.
- KÄYTTÖOLOSUHTEET: Lämpötila: 15 ÷ 35 °C. Kosteus: 20 ÷ 80 % S.K. tiivistymätön.

10.3 Jos kone on vahingoittunut

Kytke Vision X irti sähköverkosta ja anna huolto pätevän henkilökunnan tehtäväksi seuraavissa olosuhteissa:

- Jos virtajohto on vahingoittunut tai kulunut.
- Jos tuotteeseen on valunut nestettä.
- Jos laitteisto on ollut sateessa tai vedessä.
- Jos laitteisto ei toimi normaalisti kun käyttöohjeita noudatetaan.
- Jos laite on pudonnut tai vaurioitunut.
- Jos laitteen tehossa havaitaan selvä muutos, joka osoittaa, että huoltoa tarvitaan.

Säädä ainoastaan sellaisia asetuksia ja vaihda ainoastaan sellaisia osia, jotka kuvataan tässä oppaassa.

Jos yrität tehdä muita kuin tässä oppaassa kuvattuja säätöjä, laite voi vahingoittua ja takuu raukeaa.

Valtuuttamattomat säädöt tai korjaukset voivat johtaa tilanteeseen, jossa vaaditaan pätevän teknikon työskentelyä laitteen palauttamiseksi oikeisiin toimintaolosuhteisiin.

10. Σωστή απόρριψη των (WEEE)

ΓΙΑ ΧΩΡΕΣ ΣΤΗΝ ΕΥΡΩΠΑΪΚΗ ΕΝΩΣΗ (ΕΕ)

Η Ευρωπαϊκή Επιτροπή της Ευρωπαϊκής Ένωσης έχει καθορίσει ότι οι ηλεκτρικές και ηλεκτρονικές συσκευές στην αγορά σήμερα περιέχουν μέρη και εξαρτήματα τα οποία μπορούν να επαναχρησιμοποιηθούν ή να ανακυκλωθούν κατάλληλα για να μειωθούν οι ποσότητες των υλικών που τελικά απορρίπτονται σε χωματερές και άλλους χώρους απόρριψης. Για να εξυπηρετηθεί αυτή η απόφαση, τα απόβλητα ηλεκτρικού και ηλεκτρονικού εξοπλισμού (WEEE) δεν πρέπει να συλλέγονται ή να απορρίπτονται μαζί με τα απορρίμματα που δεν έχουν υποστεί διαλογή από ιδιωτικές κατοικίες ή επιχειρήσεις. Αντίθετα, πρέπει να συλλέγονται ξεχωριστά. Η απόρριψη αυτών των συσκευών σε χώρους χωρίς κατάλληλο εξοπλισμό ή εξουσιοδότηση μπορεί να έχει επικίνδυνες επιπτώσεις στην υγεία και το περιβάλλον. Οι παραβάτες θα υπόκεινται σε ποινές και μέτρα που καθορίζει η νομοθεσία.

Προς το σκοπό αυτό, τα προϊόντα της Panini φέρουν την κατάλληλη σήμανση με το σύμβολο του διαγραμμένου κάδου απορριμμάτων της Οδηγίας (WEEE) της Ευρωπαϊκής Ένωσης, για να υποδεικνύουν την ανάγκη για ξεχωριστή συλλογή του ηλεκτρικού και ηλεκτρονικού εξοπλισμού που κυκλοφόρησε στην αγορά μετά τις 13 Αυγούστου 2005, σύμφωνα με την οδηγία (WEEE) 2002/96/ΕΚ (και τις επακόλουθες τροπολογίες της) και την εθνική σας νομοθεσία.

Για να απορριφθούν σωστά οι συσκευές μας:

- Επικοινωνήστε με τις τοπικές αρχές ή τον τοπικό αντιπρόσωπο, οι οποίοι θα σας δώσουν τις πρακτικές συμβουλές που χρειάζεστε και τις οδηγίες για το σωστό χειρισμό των αποβλήτων, για παράδειγμα: τοποθεσίες και ώρες λειτουργίας των κέντρων συλλογής απορριμμάτων, κλπ.
- Όταν αγοράζεται μια καινούρια συσκευή μας, παραδώστε μια μεταχειρισμένη συσκευή παρόμοια με εκείνη που αγοράσατε στον αντιπρόσωπό μας για απόρριψη..



ΓΙΑ ΑΛΛΕΣ ΧΩΡΕΣ (ΟΧΙ ΣΤΗΝ ΕΕ)

Η επεξεργασία, συλλογή, ανακύκλωση και απόρριψη των ηλεκτρικών και ηλεκτρονικών συσκευών θα πραγματοποιείται σύμφωνα με την ισχύουσα νομοθεσία στη συγκεκριμένη χώρα.

10.1 Αποδέκτες

Το εγχειρίδιο αυτό γράφτηκε κυρίως για το προσωπικό που χειρίζεται τους ελέγχους ή άλλα έγγραφα.

10.2 Προφυλάξεις ασφαλείας

Πριν ξεκινήσετε τη λειτουργία ή το σέρβις του Vision X σύμφωνα με τις οδηγίες του παρόντος εγχειριδίου, παρακαλούμε βεβαιωθείτε ότι διαβάσατε και κατανοήσατε αυτές τις σημαντικές οδηγίες ασφαλείας.

- Ασφάλεια ένδυσης. Μη φοράτε χαλαρά ρούχα, μακριά μαλλιά ή κοσμήματα τα οποία μπορεί να μπλεχτούν σε κινούμενα μέρη.
- Μην αφήνετε τίποτε να ακουμπά πάνω στο καλώδιο τροφοδοσίας. Μην τοποθετείτε το Vision X σε σημείο όπου κάποιος μπορεί να πατήσει πάνω στο καλώδιο τροφοδοσίας.
- Πάντοτε αποσυνδέετε το Vision X από την πρίζα πριν τον καθαρισμό.
- Μην προσπαθήσετε να επισκευάσετε ή να συντηρήσετε το Vision X, με εξαίρεση τις οδηγίες που παρέχονται σε άλλο σημείο του παρόντος εγχειριδίου.
- Η προσπάθεια συντήρησης ή επισκευής της εξωτερικής παροχής τροφοδοσίας του Vision X μπορεί να σας εκθέσει σε σημεία με επικίνδυνες τάσεις ή άλλους κινδύνους.
- Αναθέστε κάθε συντήρηση σε εξειδικευμένο προσωπικό σέρβις.

Σημείωση:

- Το Vision X θα είναι σύμφωνο με το πρότυπο IEC/EN 60950-1 και UL 60950-1 χρησιμοποιώντας μόνο το μοντέλο Παροχής Τροφοδοσίας DSA-0421S-28 1 42 που διατίθεται με το μηχάνημα.
- Ο ρευματολήπτης θα πρέπει να είναι εγκατεστημένος κοντά στον εξοπλισμό και να είναι εύκολα προσβάσιμος.
- ΣΥΝΘΗΚΕΣ ΛΕΙΤΟΥΡΓΙΑΣ: Θερμοκρασία: 15 ÷ 35°C. Υγρασία: 20 ÷ 80%. Σ.Υ. Χωρίς συμπύκνωση.

10.3 Εάν το μηχάνημα πάθει ζημιά

Αποσυνδέστε το Vision X από την πρίζα στον τοίχο και αναθέστε τη συντήρηση σε εξειδικευμένο προσωπικό σέρβις υπό τους παρακάτω όρους:

- Εάν το καλώδιο τροφοδοσίας έχει υποστεί ζημιά ή έχει ξεφτίσει.
- Εάν έχει χυθεί υγρό πάνω στο προϊόν.
- Εάν η συσκευή εκτέθηκε σε βροχή ή νερό.
- Εάν η συσκευή δε λειτουργεί κανονικά όταν ακολουθούνται οι οδηγίες λειτουργίας.
- Εάν η συσκευή έπεσε ή έπαθε ζημιά.
- Εάν η συσκευή παρουσιάσει σαφή αλλαγή στην απόδοση, υποδεικνύοντας την ανάγκη για σέρβις.

Ρυθμίστε μόνο εκείνα τα χειριστήρια και αντικαταστήστε μόνο εκείνα τα εξαρτήματα τα οποία καλύπτονται από τις οδηγίες του παρόντος εγχειριδίου.

Εάν προσπαθήσετε να κάνετε ρυθμίσεις οι οποίες δεν καλύπτονται στο παρόν εγχειρίδιο, μπορεί να προκαλέσετε βλάβη στη συσκευή και να ακυρώσετε την εγγύηση.

Οι μη εξουσιοδοτημένες ρυθμίσεις μπορεί να προκαλέσουν την ανάγκη για εκτενή εργασία από εξειδικευμένο τεχνικό για την αποκατάσταση της συσκευής στην κανονική κατάσταση λειτουργίας της.



Advanced Solutions
for Document Processing

Vision | **X**

10. WEEE指令による電気・電子器具廃棄物の適正処理





Advanced Solutions
for Document Processing



10.1 本書の対象となる主体

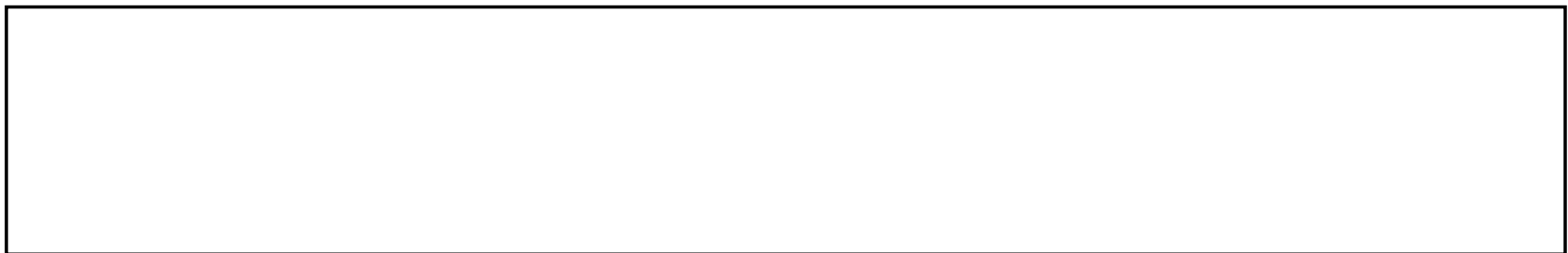



Advanced Solutions
for Document Processing

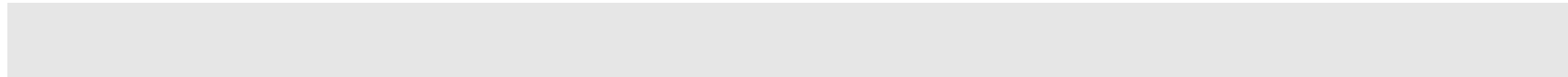

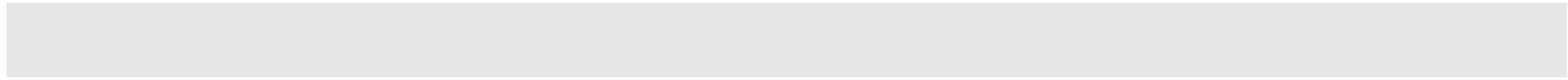



Advanced Solutions
for Document Processing

Vision | X

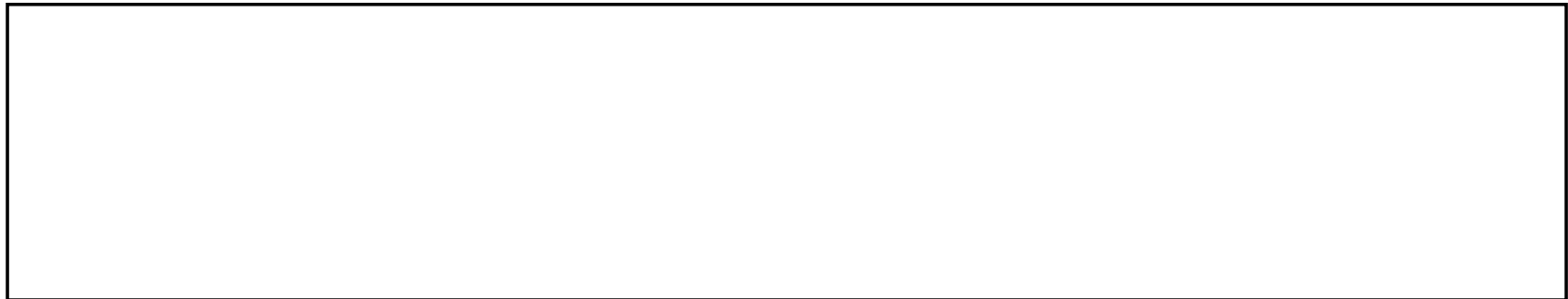
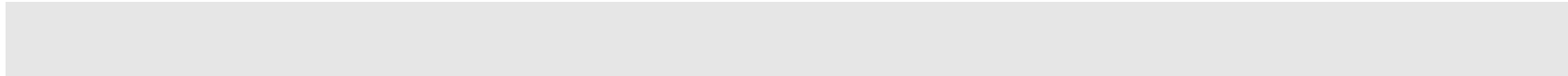



Advanced Solutions
for Document Processing

Vision | X

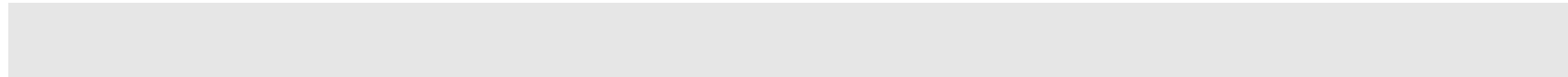

Deal

panini.com



Operator Manual

Rev. 1.5



Advanced Solutions
for Document Processing

Preface

Release Date:
March 2011

© 2011
PANINI SpA
Via Po, 39
10124 Torino Italy
Internet: www.panini.com

**PANINI NORTH
AMERICA**
(Subsidiary)
577 Congress Park Drive
Dayton, OH 45459
(USA)

This manual and the software described in it are protected under the Panini S.p.A Copyright. All rights reserved. Reproduction of this material in any form without the express written consent of Panini SpA or its subsidiaries is prohibited.

PANINI SpA PROVIDES THIS MANUAL "AS IS" WITHOUT WARRANTY OF ANY KIND, EXPRESS OR IMPLIED, INCLUDING, BUT NOT LIMITED TO THE IMPLIED WARRANTIES OF MERCHANTABILITY AND FITNESS FOR A PARTICULAR PURPOSE. PANINI SpA MAY MAKE IMPROVEMENTS AND OR CHANGES IN THE PRODUCT(S) AND OR THE PROGRAM(S) DESCRIBED IN THIS MANUAL AT ANY TIME AND WITHOUT NOTICE.

This manual could contain technical inaccuracies or typographical errors. Changes are periodically made to the information herein; these changes will be incorporated in new editions of this publication.

Trademark Acknowledgements

PANINI. I:Deal. Vision API, ICR Vision and MICR Plus are trademarks or registered trademarks of Panini SpA.

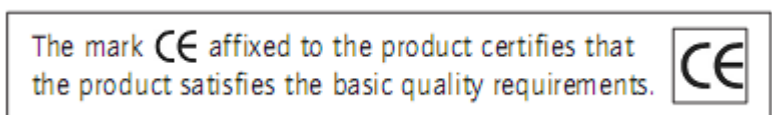

The Panini I:Deal™ is also UL 950 compliant

Note: This equipment has been tested and found to comply with the limits for a Class B digital device, pursuant to part 15 of the FCC Rules. These limits are designed to provide reasonable protection against harmful interference in a residential installation. This equipment generates, uses and can radiate radio frequency energy and, if not installed and used in accordance with the instructions, may cause harmful interference to radio communications. However, there is no guarantee that interference will not occur in a particular installation. If this equipment does cause harmful interference to radio or television reception, which can be determined by turning the equipment off and on, the user is encouraged to try to correct the interference by one or more of the following measures:

- Reorient or relocate the receiving antenna.
- Increase the separation between the equipment and receiver.
- Connect the equipment into an outlet on a circuit different from that to which the receiver is connected.
- Consult the dealer or an experienced radio/TV technician for help.

Modifications not expressly approved by the manufacturer could void the user's authority to operate the equipment under FCC rules.

© 2011 PANINI S.p.A., ALL RIGHTS RESERVED

Proper Disposal of WEEE

FOR COUNTRIES IN THE EUROPEAN UNION (EU)

The European Commission of the European Union has determined that electrical and electronic equipment on the market today contain parts and components that may be properly reused or recycled to reduce quantities of materials ultimately disposed in landfills and other disposal arenas. To address this determination, waste electrical and electronic equipment (WEEE) should not be collected or disposed with unsorted waste from private households or businesses. Rather, it must be collected separately. Dumping of these devices at unequipped and unauthorized places may have hazardous effects on health and environment. Offenders will be subjected to the penalties and measures laid down by the law.

To that end, Panini products are appropriately marked with the European Union WEEE Directive's crossed-out dustbin symbol to indicate the requirement for separate collection of electrical and electronic equipment put on the market after August 13, 2005, according to the WEEE directive 2002/96/EC (and subsequent amendments) and your national laws.

To dispose of our devices correctly:

Contact the Local Authorities or local distributor, who will give you the practical information you need and the instructions for handling the waste correctly, for example: location and times of the waste collection centres, etc.

When you purchase a new device of ours, give a used device similar to the one purchased to our distributor for disposal.

FOR OTHER COUNTRIES (NOT IN THE EU)

The treatment, collection, recycling and disposal of electric and electronic devices will be carried out in accordance with the laws in force in the country in question.

Contents

Preface	1
1. Preparation	3
1.1. Packaging List	3
1.2. External Components	3
1.3. Internal Components	3
1.4. Safety Precautions	3
1.5. If the Machine is Damaged	3
2. Installation	4
2.1. Choose a Location	4
2.2. Unpack the Scanner	4
2.3. Connect Cables	4
2.4. Install Franking Roller (optional)	5
3. Operating the I:Deal™	6
3.1. Preparing Documents	6
3.2. Feeding Documents	6
3.3. LED Indicators	7
3.4. Document Processing / LED Cycle	7
3.5. Opening / Closing Top Cover	7
4. Maintenance	8
4.1. Cleaning the Scanner	8
4.2. Cleaning the Contact Image Sensors	8
5. Troubleshooting	9
5.1. Clearing Jams	9
5.2. Feeding Issues	9
5.3. Image Streaking or Fading	9
6. Specifications	10
6.1. Technical Specifications	10
6.2. Warranty	11

Thank you for purchasing the Panini I:Deal™, a breakthrough and revolutionary product that will provide a compelling check capture solution designed specifically for the needs of small-business users of remote deposit capture (RDC).

The new device, through patented technologies, features:

- Innovative paper handling, including document auto-alignment
- High quality dual-sided image capture
- Advanced reading technologies in the areas of MICR and OCR
- Document franking
- Virtual endorsement
- Pocketing capability, providing document storage while ensuring transaction sequence integrity
- Outstanding performance in all critical functions of distributed capture

Please read this manual thoroughly before operating the machine in order to familiarize yourself with its capabilities and understand proper handling of its many functions.

1. Preparation

This chapter describes necessary preparations before using the I:Deal™.



Do not connect the device to your PC before installing the device drivers. If the device is connected before installing the drivers, it will not operate correctly.

Refer to Chapter 2 for the device installation instructions.

1.1. Packaging List

The Panini I:Deal™ packaging includes:

- Panini I:Deal™ scanner unit
- Power Supply
- USB Cable
- Operator Manual CD
- Quick Guide
- Franking Roller (optional)

1.2. External Components

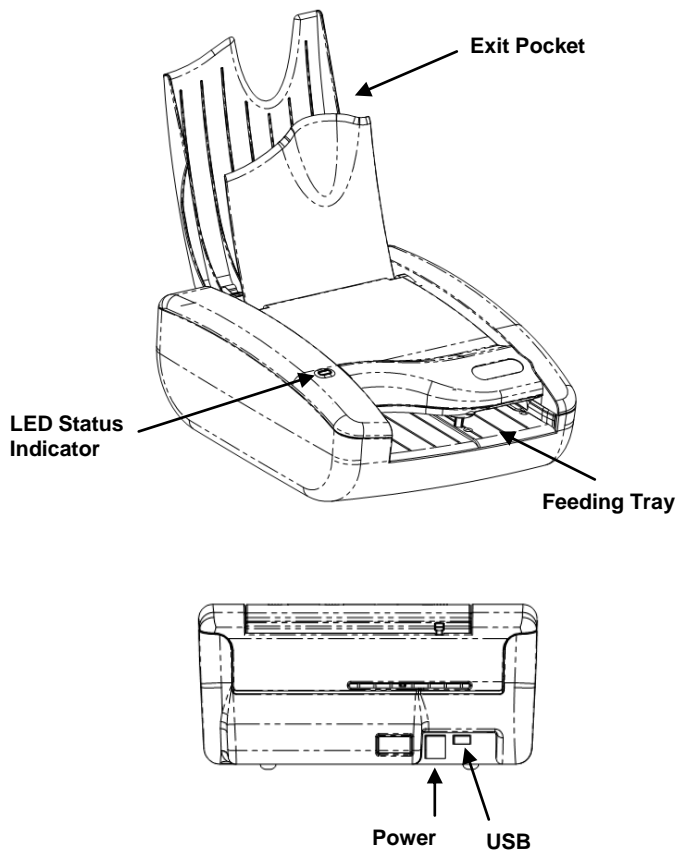

1.3. Internal Components

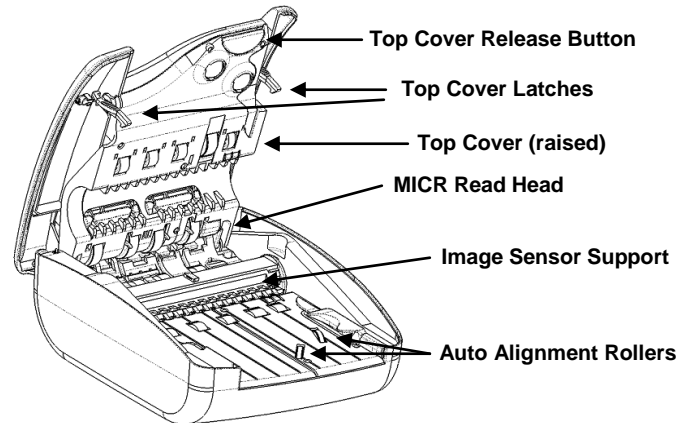

1.4. Safety Precautions

Before you begin operating or servicing your I:Deal™ as instructed in this manual, please make sure you read and understand these important safety instructions.

- Do not allow anything to rest on the power cord. Do not locate the device where people may walk on the cord
- Always unplug the device before cleaning
- Do not attempt to service or repair the device, except as instructed elsewhere in this manual
- Attempting to service or repair the external power supply of the device may expose you to dangerous voltage points or other risks
- Refer all servicing to qualified service personnel

1.5. If the Machine is Damaged

Unplug the device from the wall outlet and refer servicing to qualified personnel under the following conditions:

- If the power cord is damaged or frayed
- If liquid has been spilled into the product
- If the equipment has been exposed to rain or water
- If the equipment does not operate normally when the operating instructions are followed
- If the equipment has been dropped or damaged
- If the equipment exhibits a distinct change in performance, indicating a need for service

Adjust only those controls and replace only those items that are covered by the instructions in this manual. If you attempt to make adjustments not covered in this manual, you may damage the equipment and void the warranty.

Unauthorized adjustments or repairs may result in the need for extensive work by a qualified technician to return the equipment to its proper working condition.

2. Installation

To set up the Panini I:Deal™ follow the steps below.

2.1. Choose a Location

Place the device on a level surface on or near the host computer, such as a countertop or table, away from direct light. Leave enough space to open the pocket flaps, top cover and to insert documents.

The device should be located as to minimize Electro-Magnetic Interference (EMI). Keep the device a minimum of 1 foot away from CRT monitors that can produce interference and affect the MICR reading.

2.2. Unpack the Scanner



Before unpacking the box, examine it for damage received during shipping. If the device, or any component, appears damaged do not use it. File a claim with the shipping company and contact your distributor.

When you unpack the I:Deal™, make sure that all parts are included (see packaging list from section 1.1). Save all packaging materials in case you need to repack the scanner.

- 1.) Open the top of the box



- 2.) Remove and unwrap the items



2.3. Connect Cables

Ensure that the device drivers have been preinstalled on the PC. The device drivers are widely available through supported software applications or by directly installing Panini's Vision API. Device drivers are available for Windows XP, Windows Vista and Windows 7.



Power Connection

USB Interface

Power Cable Connection

- 1.) Plug the power supply cable in the I:Deal™ power connector
- 2.) Connect the I:Deal™ to a dedicated electrical power outlet. The socket outlet needs to be installed near the equipment and be easily accessible. The power supply will be 100-240 VAC (no power selection required), and the frequency 50/60 Hz. If you are not sure of the type of power available, consult your Service Representative or local power company.

USB Cable Connection

Connect the USB cable to the USB port located on the rear side of the scanner, and then connect the other end of the cable to an available USB 2.0 port on the PC.

Windows will detect the newly connected hardware and initiate the "New Hardware Wizard". The Microsoft signed drivers previously installed on the PC will be recognized and the device will be successfully installed.

When removing or disconnecting the USB or Power Supply Cable from the device, be sure to pull straight back on the cable and remove.

DO NOT remove the cable by pulling up, vertically or at an angle. Doing so can damage the connector. The cables must be removed by gently pulling straight back on the cable from the connector.

2.4. Install Franking Roller (optional)

The optional Franking Roller is an ink stamp which can be used to mark the front of a document to read “ELECTRONICALLY DEPOSITED”.

Follow these steps to insert the franking roller into the device.

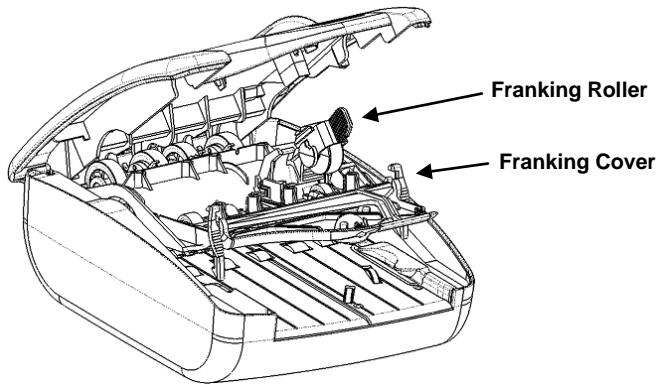

Open the Franking Cover

1.) Open the top cover by pressing the top cover release button and lifting the cover



2.) Open the franking cover by pressing forward on the top cover latches and pulling the franking cover down



Insert the Franking Roller

1.) Insert the Franking Roller straight into the roller harness, aligning the assembly guides on both sides



2.) Align the roller notch to fit into the positioning tab



3.) Apply pressure to the handle until the roller clicks into place

4.) Close the franking cover by pushing it up until it clicks into place

5.) Close the top cover. Press firmly in the middle of the scanner to securely close the top cover.



6.) After replacing franking roller, connect device and perform franking on a test document. Sample franking will ensure the correct position and confirm proper installation of the roller.



CAUTION

- Avoid contact with the main drive roller to prevent ink transfer to documents
- Ink may be harmful if swallowed
- Avoid contact with eyes
- Damage to the unit or the roller resulting from modifying the roller is not the responsibility of Panini

3. Operating the I:Deal™

3.1. Preparing Documents

To reduce the possibility of transport errors and damage to the unit, you should perform the following steps prior to feeding the documents:

- Remove all folds and creases in the document
- Remove any paper clips, staples, pins, rubber bands, etc. from the document

3.2. Feeding Documents

The unit is designed to make feeding as easy and hassle free as possible. The steps below instruct how to properly feed documents into the unit.

- To begin feeding first open the feeding pocket flaps by lifting up on the flap handle.



Once the software calls the feeding process and the LED is green then the I:Deal™ unit is ready to accept documents.

- Insert document face up with the MICR line aligned to the right side of the scanner into the right side of the feeding tray (as indicated by the check icon).



- Once the document is inserted, the machine will detect the presence of the document and will begin feeding. The device will automatically align the document to the proper position regardless of the angle or alignment in which the document is inserted into the unit.
- The document is scanned and, depending on the scan mode selected by the application, will either scan and stop in the exit pocket (which holds up to 10 documents) or scan and return to the feeding tray for easy removal.

As the document is fed into the device the machine will detect if the document was not automatically aligned correctly. If the document is skewed the device will prevent further processing, stopping the document and flashing a red LED. Document can be fed again by removing and reinserting the document.

3.3. LED Indicators

The 3-color LED on the top cover of the device indicates the machine's status. The following table indicates the meaning of each status light.



LED	Description
Off	Device disconnected or software not connected
Yellow Blinking	Device connected, software connected but pocket flaps are closed
Yellow Solid	Device connected, software connected, pocket flaps open
Green Solid	Device is ready to begin feeding (Device connected, software connected, pocket flaps open and feeding enabled)
Green Blinking	Machine is processing documents
Red Blinking	Document jam or misalignment
Red Solid	Firmware being updated

3.4. Document Processing / LED Cycle

- 1.) Once the unit is powered on, flaps are up and USB cable connected the status LED will turn solid yellow, indicating initial power and PC connection to the device.
- 2.) When the application requests to start feeding the LED will turn solid green. Once a document is loaded into the feeding tray the machine will detect the document and begin scanning. The LED status

will begin blinking green indicating that the machine is busy processing a document.

- 3.) After scanning the machine will stop with the document either in the exit pocket or feeding tray according to the processing mode. If exiting to the feeding tray the LED will continue flashing green until document is removed from the tray. Once removed the LED will have be solid green indicating it is ready to process the next document.
- 4.) A flashing red LED indicates that either a document jam or misalignment has been detected. The machine will stop the document in the track to prevent capturing a misaligned document or to prevent damaging a jammed document. If misaligned, remove document and begin scanning again. For jammed documents see section 5.1 on how to remove jammed documents.
- 5.) A flashing yellow LED indicates that either the top flaps are closed or the top cover is open.

3.5. Opening / Closing Top Cover

The top cover of the device can be easily opened for removal of jammed documents, cleaning the device or for replacing the franking roller.

- 1.) To open the top cover press the blue release button on the top side of the feeding tray and lift the cover up.



- 2.) To close the cover press firmly downwards in the middle of the top cover. Ensure that both sides of the scanner securely snap closed.



4. Maintenance

The I:Deal™ has been designed as a minimal maintenance device. As such no regular cleaning schedule has been defined. However, processing documents in a scanner can cause some paper dust or other debris which after continued use could build up to eventually lead to imaging issues. As a preventative measure to ensure the expected quality from the device a general maintenance program can help achieve optimal results and avoid unnecessary failures.



CAUTION

- Before doing maintenance, remember to disconnect the USB and power cables from the device.
- Solvents or harsh cleaners may damage or discolor the cabinetry.
- Do not spray or try to clean the Contact Imaging Sensors (CIS) or the inside of the scanner with any kind of cleaner other than what is recommended. This may damage the CIS or the electronics.

4.1. Cleaning the Scanner

- **Cleaning Inside of Unit:** Remove paper dust and small debris from device by using low pressure canned air or a dusting brush designed for use on electronic equipment.
- **Cleaning Outside of Unit:** The outside cabinetry can be cleaned to remove finger marks and dust with a damp cloth and mild soap.

4.2. Cleaning the Contact Image Sensors

1.) Gently open the front image camera

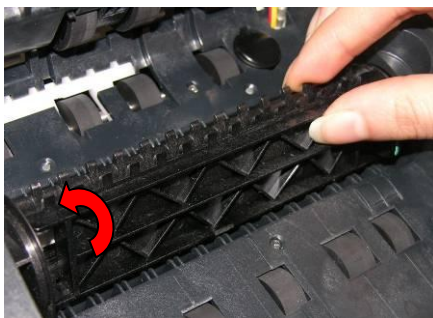

a. Manually rotate the CIS support, positioning the camera on the bottom.

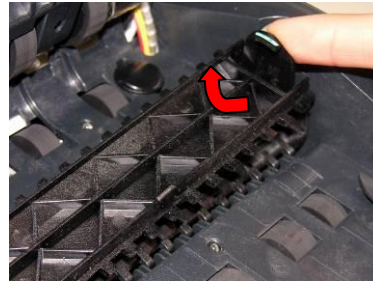

b. Open the rear CIS support by pressing the right tab in and lifting up.

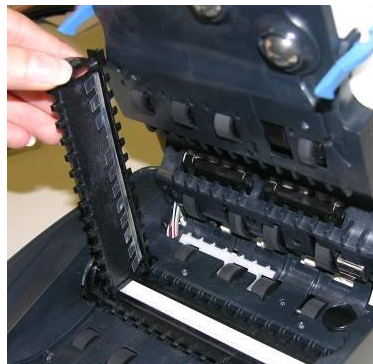

c. Hold the CIS support to clean the camera lens.

2. Remove any debris and dust. Clean the Contact Image Sensors with a soft, lint-free cloth dampened with Isopropyl Alcohol or with eye glass cleaner.

5. Troubleshooting

In the course of everyday operations, you may encounter minor issues. The topics below should be reviewed prior to calling for service on the unit.

5.1. Clearing Jams

When a jam occurs, the paper path must be cleared. The paper path can be easily accessed simply by opening the cover and extracting the jammed document simply by gently pulling it out with your fingers.



When clearing a jam clear the paper path and rollers from any documents, paper dust or debris. Close cover to resume operation.

5.2. Feeding Issues

The I:Deal™ is designed to make document feeding as hassle-free as possible. The auto align feature of the device permits inserting documents in the feeding tray at varied angles. If the position or angle of the document insertion is too extreme and the auto alignment is not able to align the document, then the skewed position of the document will be detected by the device and the I:Deal™ will stop feeding.



In this case remove and re-feed document into the scanner. Ensure that the top cover is properly closed after removing the document.

If the device fails to recognize a document when inserted into the feeding tray, try opening the scanner to remove any paper or debris. Additionally, the feeding sensor and alignment sensors can be cleaned of any dust build-up with the use of canned air.

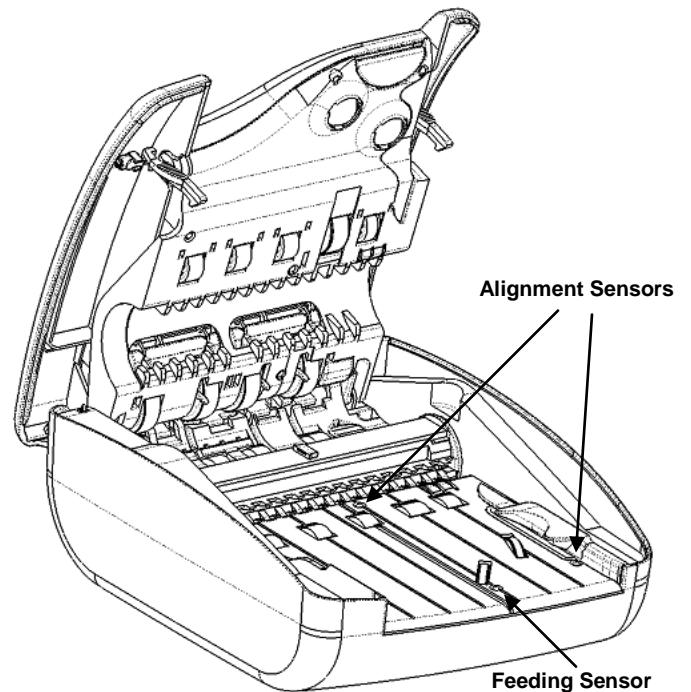

5.3. Image Streaking or Fading

If streaking or fading appears on the images, the Contact Image Sensors may require cleaning. Refer to section 4.2 for instructions on how to clean the scanners.

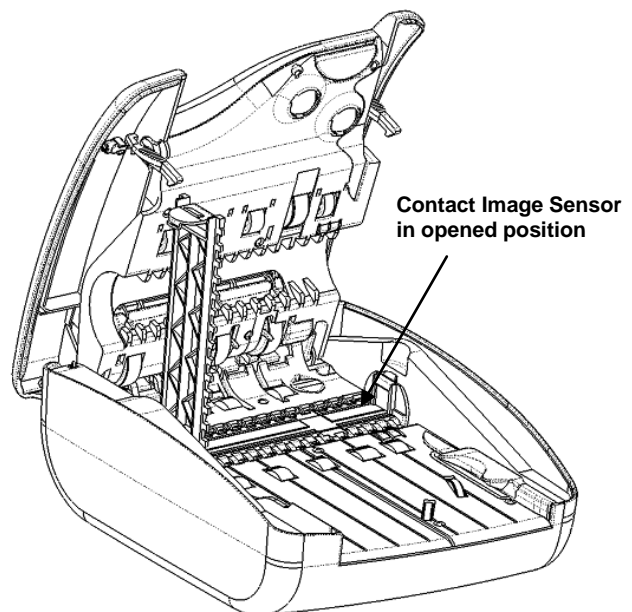

6. Specifications

6.1. Technical Specifications

Dimensions	Height: 81 mm (3.19") Width: 167 mm (6.57") Length: 201 mm (7.91")
Weight	1,05 Kg (2.3#)
Product layout	Positioned on horizontal, level surface Straight track Clam-shell structure – easy inspection No covers to remove, no extensions
Document Specifications	Height: Min. 54 mm (2.12") – Max. 106 mm (4.17") Length: Min. 100 mm (3.93") – Max. 235 mm (9.25") Weight: Min. 70 gr/m2 (18.7#) – Max. 120 gr/m2 (32#)
Document Feeder	Auto-aligning single document feeder Automatic loading, document face up
Magnetic Reader	E13B/CMC7/Automatic New Panini MICR Plus® exclusive technology with OCR assist feature Superior MICR recognition and management
Image Capture	Scanning: Contact Image Sensor (CIS) technology; dual sided image capture Image format: Bitmap in B/W, 256 shades of gray, TIFF, JPEG and Group IV compression Image resolution: 300 dpi optical, scalable to 200 or 100 dpi Advanced Dynamic Thresholding Superior auto calibrated image quality Dual image: 4 images plus a maximum of 10 uncompressed snippets per document
Front-side Franking	Self-inking roll-on stamp, red color Intelligent franking (based on codeline contents, image contents, IQA controls) Possibility to capture franked front image with an additional pass Ink roller (not included) life: up to 10,000 impressions, subject to environmental conditions Standard text: / ELECTRONICALLY DEPOSITED / <i>For customized text please contact your Sales representative</i>
Virtual Endorsement	Up to 8 different virtual endorsements applicable to rear document image User can select: - multi-line text and/or bitmap - endorsement area (3 pre-defined following ANSI X9 standard for US checks; 5 customizable) - font and color - rotation (0, 90, 180 or 270°)
Interface	USB 2.0 port
Pockets	Exit pocket capable of holding up to 10 documents with sequence integrity Intelligent sorting to send document to either exit pocket or back to feeding tray
Software Tools	Panini Vision API control running on: Windows XP SP1, Windows Vista and Windows 7 with USB 2.0 ICR Vision function for image snippet definition and download Easy integration of ICR/Barcode/OCR recognition technology
Software Options	OCR Recognition: OCR-A, OCR-B recognition engine Barcode Recognition: Code 39, Interleaved 2/5, EAN8, EAN13, UPCA, UPCE, Code 128 Bi-dimensional barcode (PDF417) Image Quality Assurance (IQA) library
PC Minimum Requirements	Intel Pentium IV, 2 GHz, 512 Megabytes Ram
Diagnostic Features	On board Diagnostics: tests the functionality of the scanner Power-on Self Testing: automatic self testing and photocells calibration when powering the unit
Power Supply Input Voltage	Autosensing from 100 to 240 Vac, 50 to 60 Hz 24 W Meets CEC IV
Operating Conditions	Operating: 15 ÷ 35 °C, 20 ÷ 80 % RH Non-Condensing Storage: 0 ÷ 40 °C, 10 ÷ 80 % RH Non-Condensing Altitude: 0 ÷ 3000 meters
Product Life	MCBF: 100,000 documents or 4 years Designed for low-end Remote Deposit Capture applications Minimal maintenance requirements
Certifications	UL / FCC Class B / CE Electronics and mechanics following the European RoHS and WEEE Directives

6.2. Warranty

Panini SpA warrants that, on the date of purchase, the product shall comply with its technical specifications and be free from defects in workmanship and material. Panini SpA warrants the product as such, meaning not in the guise of components, spare parts or consumables.

The standard warranty period for each product is of 12 (twelve) months from the date of purchase. However, to the extent a different warranty period is granted by Panini SpA under a specific agreement or by any reseller, dealer or distributor, the latter shall apply.

For avoidance of doubt, Panini SpA shall have no liability if the product has been damaged by any force or occurrence beyond its control, including, without limitation, accident, abuse, misuse, improper warehousing, conservation, repair, service or maintenance, modification or alteration by third parties, combination with other products, normal wear and tear.

In principle, notice of the non-compliance or of the defects shall be sent to the location indicated, as the case may be, by the reseller, the dealer, the distributor or Panini SpA within 10 (ten) days from the date on which you will have discovered the lack of compliance or the defect. Upon receipt of a warranty claim, it shall be promptly verified if the allegedly non-compliant or defective product is still under warranty and, if that should be the case, the shipment thereof shall be authorized. You will be assigned a specific code in such respect and you shall ship the allegedly non-compliant or defective product to the location indicated. Should the product be found to be non-compliant or defective, it shall be replaced or repaired free of charge, and returned to you.

In any case, please refer to your reseller, dealer or distributor for returning the product under warranty and for related shipment costs and expenses, where applicable.

Except as provided for herein, Panini SpA disclaims all other warranties or any express, implied or statutory remedies regarding the product, including any warranty of merchantability and fitness for a particular purpose. You acknowledge that you have relied on no other warranties or remedies other than those expressly provided for herein. In no event, shall Panini SpA be liable for any indirect, incidental or consequential damages or loss of profit, loss of data or loss of opportunities.

This warranty does not limit in any manner whatsoever, to the extent applicable, the rights granted under local mandatory laws, including those concerning the sale of consumer goods.



Copyright© Panini S.p.A., 2011. All rights reserved.

PANINI and I:Deal are trademarks or registered trademarks of Panini SpA.

PANINI S.p.A.

(Corporate Headquarters)

Via Po, 39

10124 Torino Italy

website: www.panini.com

PANINI North

America

(Subsidiary)

577 Congress Park Drive

Dayton, OH 45459

(USA)

PANINI Limitada

(Subsidiary)

Rua Joaquim Floriano,

871 – 11^ªA

São Paulo

Brazil